

# Troubleshooting Terminal, Printer, and Serial Device Connections

**HP 3000 MPE/iX Computer Systems**

**Edition 5**



**Manufacturing Part Number : 32022-90058**

**E0604**

U.S.A. June 2004

---

## Notice

The information contained in this document is subject to change without notice.

Hewlett-Packard makes no warranty of any kind with regard to this material, including, but not limited to, the implied warranties of merchantability or fitness for a particular purpose. Hewlett-Packard shall not be liable for errors contained herein or for direct, indirect, special, incidental or consequential damages in connection with the furnishing or use of this material.

Hewlett-Packard assumes no responsibility for the use or reliability of its software on equipment that is not furnished by Hewlett-Packard.

This document contains proprietary information which is protected by copyright. All rights reserved. Reproduction, adaptation, or translation without prior written permission is prohibited, except as allowed under the copyright laws.

### Restricted Rights Legend

Use, duplication, or disclosure by the U.S. Government is subject to restrictions as set forth in subparagraph (c) (1) (ii) of the Rights in Technical Data and Computer Software clause at DFARS 252.227-7013. Rights for non-DOD U.S. Government Departments and Agencies are as set forth in FAR 52.227-19 (c) (1,2).

Hewlett-Packard Company  
3000 Hanover Street  
Palo Alto, CA 94304 U.S.A.

© Copyright 1990–1993, 1998 and 2004 by Hewlett-Packard Company.

**1. General Information**

|   |    |
|---|----|
| Datacommunications and Terminal Subsystem (DTS) ..... | 16 |
| Datacommunications and Terminal Controller. ....      | 16 |
| ASC Software .....                                    | 20 |
| Powerfail Recovery .....                              | 21 |
| Troubleshooting Responsibilities .....                | 22 |
| Basic Troubleshooting .....                           | 22 |
| More Troubleshooting .....                            | 22 |
| Hewlett-Packard Responsibilities .....                | 23 |

**2. Troubleshooting Procedures**

|                                      |    |
|--------------------------------------|----|
| Troubleshooting Pathway .....        | 26 |
| Troubleshooting the Device .....     | 28 |
| Testing DTC Device Connections ..... | 29 |
| Testing the DTC .....                | 31 |
| Testing the LAN .....                | 32 |

**3. Introduction to TermDSM**

|   |    |
|---|----|
| TermDSM Requirements .....                  | 34 |
| User Capabilities and Security Levels ..... | 34 |
| A Word of Caution .....                     | 34 |
| TermDSM Functionality .....                 | 36 |
| TermDSM Command Summary .....               | 37 |
| Starting TermDSM .....                      | 39 |
| Stopping TermDSM .....                      | 40 |

**4. TermDSM Commands**

|                          |    |
|--------------------------|----|
| CONNECTION .....         | 42 |
| Syntax .....             | 42 |
| Description .....        | 42 |
| SHOW .....               | 42 |
| DI[AG] .....             | 45 |
| Syntax .....             | 45 |
| Description .....        | 45 |
| DI[AG] EXT[ERNAL] .....  | 45 |
| DI[AG] I[NTERNAL] .....  | 46 |
| DI[AG] PR[INT] .....     | 47 |
| DI[AG] SE[LFTEST] .....  | 49 |
| DI[AG] T[ERMINAL] .....  | 50 |
| DI[AG] XI[NTERNAL] ..... | 51 |
| DI[AG] XE[XTERNAL] ..... | 52 |
| DI[AG] XN[ETWORK] .....  | 53 |
| DT[C] .....              | 55 |
| Syntax .....             | 55 |
| Description .....        | 55 |
| DU[MP] .....             | 56 |

---

# Contents

|                                |    |
|--------------------------------|----|
| Syntax .....                   | 56 |
| Description .....              | 56 |
| DU[MP] DT[C] .....             | 57 |
| DU[MP] LD[EV] .....            | 58 |
| DU[MP] M[UX] .....             | 59 |
| DU[MP] PO[RT] .....            | 59 |
| DU[MP] SN[P] .....             | 60 |
| DU[MP] V[C] .....              | 61 |
| EE[PROM] DT[C] .....           | 62 |
| Syntax .....                   | 62 |
| Parameter .....                | 62 |
| Description .....              | 62 |
| EX[IT] .....                   | 63 |
| Syntax .....                   | 63 |
| H[ELP] .....                   | 64 |
| Syntax .....                   | 64 |
| MULTI .....                    | 65 |
| Syntax .....                   | 65 |
| Description .....              | 65 |
| START or STOP .....            | 65 |
| DTC .....                      | 66 |
| R[ESET] .....                  | 67 |
| Syntax .....                   | 67 |
| Description .....              | 67 |
| R[ESET] DT[C] .....            | 67 |
| R[ESET] L[DEV] .....           | 68 |
| R[ESET] PO[RT] .....           | 69 |
| R[ESET] SI[C] .....            | 69 |
| R[ESET] SN[P] .....            | 70 |
| R[ESET] V[C] .....             | 70 |
| S[TATUS] .....                 | 72 |
| Syntax .....                   | 72 |
| Description .....              | 72 |
| S[TATUS] DT[C] .....           | 72 |
| S[TATUS] PO[RT] .....          | 73 |
| S[TATUS] SN[P] .....           | 74 |
| VC .....                       | 76 |
| Syntax .....                   | 76 |
| Parameters .....               | 76 |
| Description .....              | 76 |
| T[RACE] .....                  | 77 |
| Syntax .....                   | 77 |
| Description .....              | 77 |
| T[RACE] TI[O] .....            | 77 |
| T[RACE] TI[O] TRACEON .....    | 78 |
| T[RACE] TI[O] TRACEOF[F] ..... | 78 |

T[RACE] TI[O] TRACES[HOW] ..... 79  
T[RACE] X2[5] ..... 79  
T[RACE] X2[5] TRACEON..... 80  
T[RACE] X2[5] TRACEOF[F] ..... 82  
X25SITE ..... 83  
    Syntax ..... 83  
    Description ..... 83  
MAP..... 84  
LIST..... 84  
STATUS..... 85

**A. TermDSM Messages**

**Glossary .....113**  
**Index .....131**



Table 3-1. Security Levels for TermDSM ..... 34





|   |    |
|---|----|
| Figure 1-1. Datacommunications and Terminal Controller..... | 16 |
| Figure 1-2. ThinLAN Configuration .....                     | 19 |
| Figure 1-3. 10/100 Base-T Topology .....                    | 20 |
| Figure 2-1. ....  | 26 |



---

## Preface

This manual documents functionality for the MPE/iX release for HP 3000 Series 900.

This manual is designed to aid the troubleshooting of device connections. Information and strategies for troubleshooting networking environments is provided. TermDSM is a utility program used to troubleshoot:

- Terminal connections.
- Printer connections.
- Other serial device connections.

This manual only covers troubleshooting connections for host-based management (i.e., when the DTCs are managed from an HP 3000 host). For troubleshooting on PC-management (when DTCs are managed by an OpenView Workstation), refer to *Using HP OpenView DTC Manager*.

---

### NOTE

MPE/iX, Multiprogramming Executive with Integrated POSIX, is the latest in a series of forward-compatible operating systems for the HP 3000 line of computers.

In HP documentation and in talking with HP 3000 users, you will encounter references to MPE XL, the direct predecessor of MPE/iX. MPE/iX is a superset of MPE XL. All programs written for MPE XL will run without change under MPE/iX. You can continue to use MPE XL system documentation, although it may not refer to features added to the operating system to support POSIX (for example, hierarchical directories).

Finally, you may encounter references to MPEV, which is the operating system for HP 3000s, not based on the PA-RISC architecture. MPE V software can be run on the PA-RISC HP 3000s (Series 900) in what is known as compatibility mode.

---

## **Skills**

*Troubleshooting Terminal, Printer, and Serial Device Connections* will be of greatest value to the person responsible for the overall operation and reliability of an MPE/iX computer. This person is usually called the system administrator or system manager, and needs to be able to prepare devices for operation and to configure the computer to recognize asynchronous devices.

## Guide To This Manual

*Troubleshooting Terminal, Printer, and Serial Device Connections* is divided into the following chapters and appendixes:

- Chapter 1, “General Information,” presents an overview of the troubleshooting environment.
- Chapter 2, “Troubleshooting Procedures,” gives information and suggests troubleshooting strategies.
- Chapter 3, “Introduction to TermDSM,” introduces the TermDSM utility program and lists the steps to start it.
- Chapter 4, “TermDSM Commands,” gives information and lists commands.
- Appendix A, “TermDSM Messages,” lists error messages returned by TermDSM and suggests causes and actions to take

## Helpful Manuals

The following manuals should be available for reference when using this manual:

- *Configuring Systems for Terminals, Printers, and Other Serial Devices* (32022-61000)
- *Asynchronous Serial Communications Programmer's Reference Manual* (32022-61001)
- *DTC Planning Guide* (D2355-95017)
- *DTC Technical Reference* (5961-9820)

This manual addresses troubleshooting from a host (and host-based management) perspective. For troubleshooting information related to PC-based management, see the *Using HP OpenView DTC Manager* manual as well as other manuals referenced earlier in this book.

This chapter provides a description of the hardware and software components of the Datacommunications and Terminal Subsystem (DTS). It also describes troubleshooting responsibilities for those most likely to become involved:

- The end user (at the device).
- The system manager.
- HP support representatives.

## Datacommunications and Terminal Subsystem (DTS)

With the exception of the system console which has its own access port, all asynchronous serial devices can be connected to HP 3000 Series 900 computers through the Datacommunications and Terminal Subsystem (DTS). DTS is made up of all of the Datacommunications and Terminal Controllers connected to the system, a LAN Interface Card, the LAN cable and the host software that controls all the related DTS hardware.

### Datacommunications and Terminal Controller

The Datacommunications and Terminal Controller (DTC) provides the connection between asynchronous devices and the HP 3000 Series 900 family of computers. The DTC can house an X.25 Network Access Card to provide connections for nailed PAD-connected terminals and printers. Also, a DTC containing a Telnet Access Card can provide Telnet connections to an HP 9000 or other ARPA machine via Telnet/iX.

The DTC is housed in its own box, outside the system cabinet. This alleviates system limitations which are based on cabinet space considerations, and allows flexibility in the layout of terminal cables. Figure 1-1 represents the location of the DTCs in relation to the system, the LAN, and the terminals and printers connected to the system through the DTCs.

Figure 1-1 Datacommunications and Terminal Controller

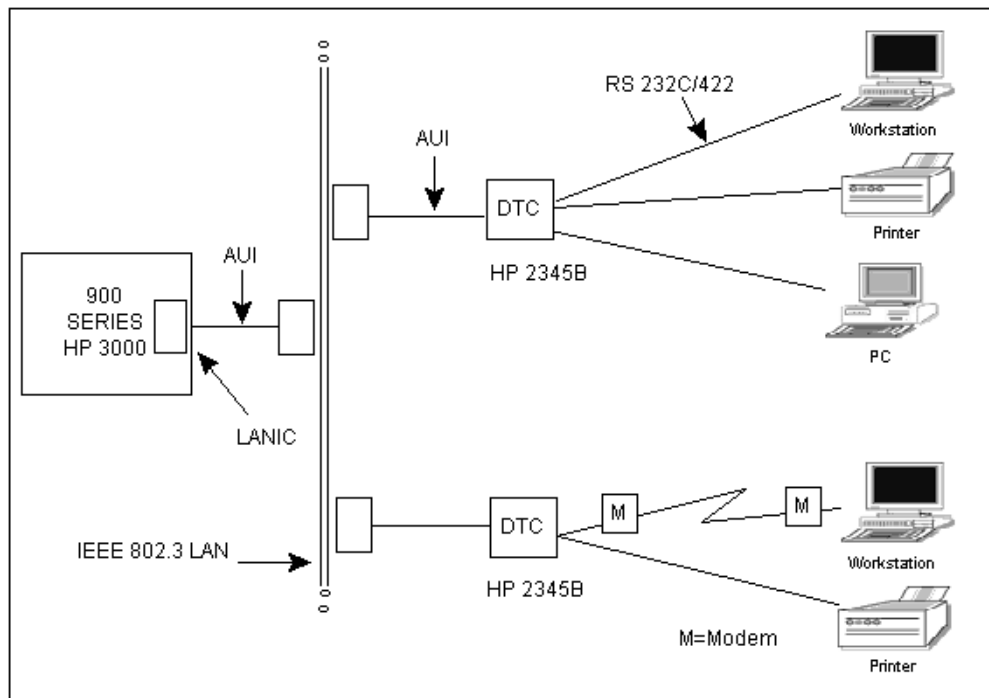

Each HP 2345B DTC (DTC 48) can provide connections for up to 48 local devices, 36 remote devices using modems, or a combination of both. For the DTC 48, up to three of the DTC's slots can contain a **DTC/X.25 Network Access card**. This card provides



access to X.25 networks, and can be used to connect asynchronous devices through PAD connections. Alternatively, a single Telnet Access Card per DTC can be used to access MPE/iX systems from ARPA systems.

Each DTC 48 provides six slots, each of which can contain one of the following connector cards:

- Eight 3-pin RS-232-C local connections.
- Eight 5-pin RS-422 local connections.
- Six 25-pin RS-232-C modem connections.
- DTC/X.25 Network Access card (up to three per DTC, slots 1 through 5 only).
- Telnet Access Card (only 1 per DTC, slots 1 through 5 only).

Each DTC 72MX can provide connections for up to 72 local and remote devices. Local and remote connections can be mixed on the same DTC, since its design is modular. Each DTC 72MX provides four slots, one slot for the LAN card, and three slots each of which can contain one of the following connector cards:

- Asynchronous processor board with three 62-pin connectors, for 24 RS-232 local or modem connections.
- Asynchronous processor board with three 62-pin connectors, for 24 RS-423A local connections.
- DTC/X.25 Network Access card (up to three per DTC).
- Telnet Access Card (only 1 per DTC).

The DTC 16 contains three slots. The first two slots and only the first two slots (card #0 and card #1) can contain direct connect or modem cards. The third slot (card #2) can contain only a DTC/X.25 Network Access Card.

Each DTC 16iX and DTC 16MX can provide RS-232 or RS-423 port connections for up to 16 asynchronous devices. They both have two port connectors built directly into their backplanes, each of which can be connected to a distribution panel which allows either all direct connections or all modem connections. The DTC 16iX does not support ARPA Telnet or X.25 connections. The DTC 16MX provides AFCP connections for the HP 3000 environment and telnet connections for the ARPA environment; it does not support X.25 connections for wide area networking. The DTC 16MX managed by an MPE/iX host is limited to identical functionality as the DTC 16iX.

The DTC is controlled by software that is downloaded by its host system at boot time or by the OpenView Windows Workstation, depending on the type of management used. Systems can use either host-based management or PC-based management. Refer to *Configuring Systems for Terminals, Printers and Other Serial Devices* for more information on host-based management and PC-based management.

The downloaded software includes DTC operating code and configuration information. Once the software is downloaded, the DTC is ready for operation. Devices physically connected to its ports and properly configured can establish communications links with the host computer.

You can troubleshoot connections with TermDSM only on systems that use host-based management. Troubleshooting for PC-based management is covered in *Using HP OpenView DTC Manager*.

### **LAN Interface Card (LANIC)**

Every computer in the HP 3000 Series 900 family has a LAN Interface Card (LANIC) as part of its hardware. This card is located in the System Processing Unit (SPU) and enables the system to communicate with asynchronous devices via the LAN by providing the basic connection between the computer and the LAN.

Datacommunications and Terminal Controllers are connected to the system by a Local Area Network (LAN), over coaxial cable which conforms to the IEEE 802.3 standard. Hewlett-Packard provides two versions of this cable, ThinLAN and ThickLAN, each provides certain specific advantages to the user.

Each DTC has a unique LAN address which is made known to the system during configuration. Also referred to as the node address or the station address, it serves to identify the DTC as a node on the LAN. Keep in mind, however, that while DTCs are treated as nodes for the purpose of configuration, they are not true nodes. DTCs are dedicated communication devices; they are not self-contained, general-purpose computer systems.

**ThinLAN Connection**

LAN cable is available in two versions. The first, ThinLAN (Type 10 BASE 2), is available in connection lengths of up to 185 meters (555 feet), and provides an economical solution where DTCs are located in close proximity to their computer system.

ThinLAN is a flexible cable which is easy to install, and can be bent around objects to accommodate its use in confined areas. ThinLAN is connected to the computer through a ThinMau (Medium Attachment Unit), with a small BNC T-connector used to connect each DTC to the LAN. You can connect up to three segments of the cable with two repeaters, thus extending the length of the LAN 555 meters. Figure 1-2 shows a configuration using ThinLAN.

**Figure 1-2 ThinLAN Configuration**

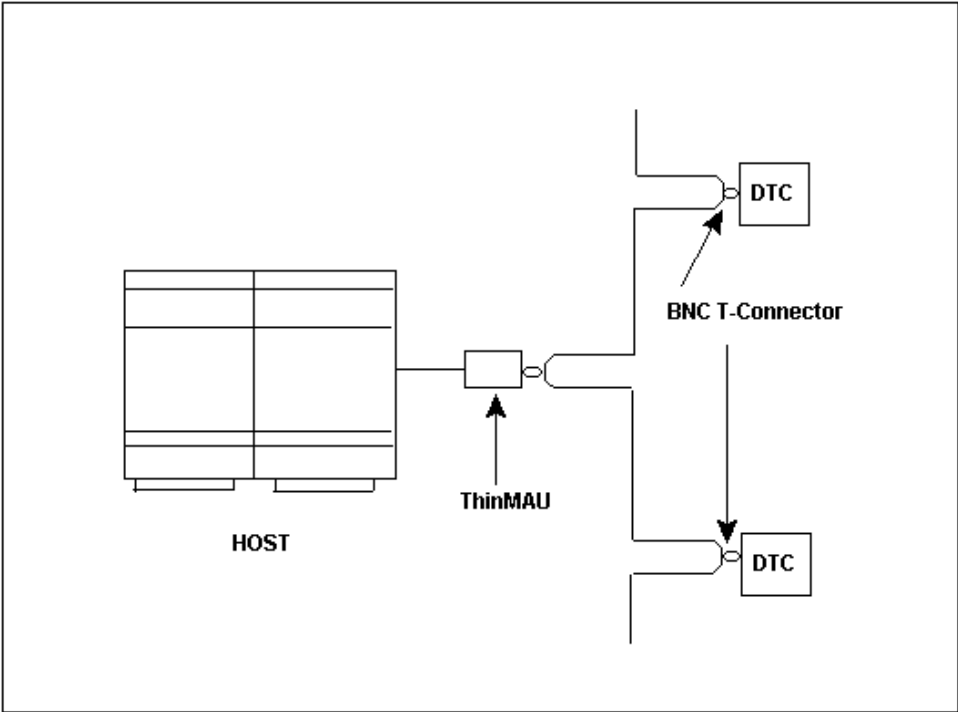

### 10Base-T and 100 Base-T

Figure 1-3 shows the star topology of the 10/100 Base-T network and offers another way to lay out your Ethernet network. 10/100 Base-T offers maximum connection lengths of up to 200 meters of unshielded twisted pair per segment and supports up to 12 workstations per HUB. You can connect multiple HUBs to the LAN with an Ethernet performance of 10 Mbps. The DTCs only support a connection at the 10 Base-T speed. The hp e3000 system can be connected to a switch that will allow the System LAN to operate using the 10 or 100 Base-T connections. The following diagram shows how to connect the DTC and system through a switch to allow the system to operate at 10 or 100 Base-T speed. Hewlett-Packard recommends that the links be operated in half-duplex mode.

**Figure 1-3** 10/100 Base-T Topology

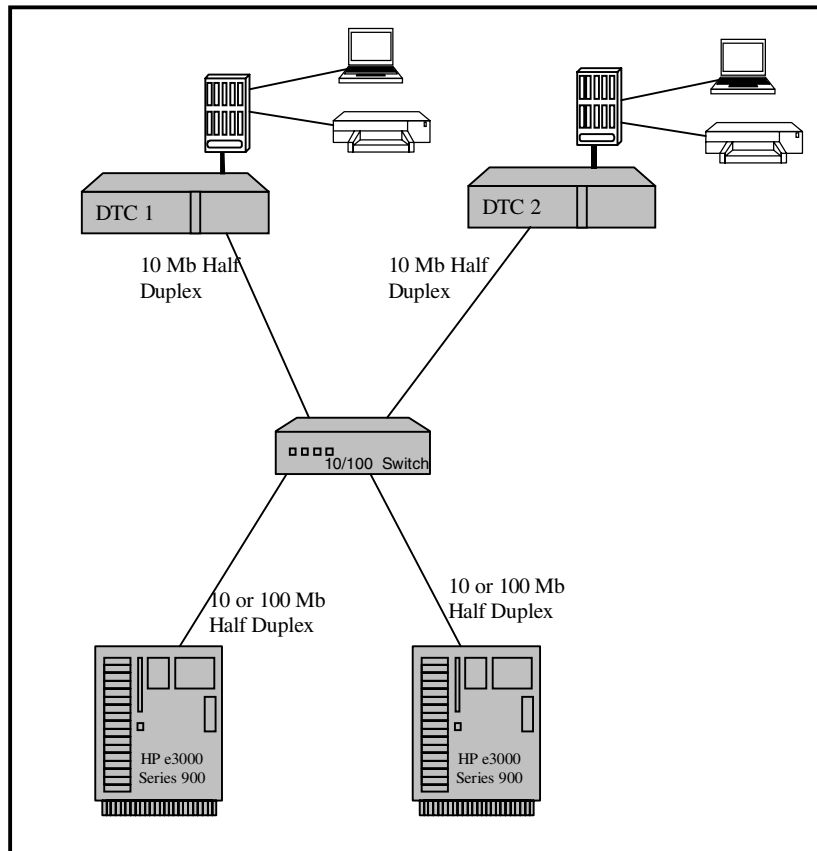

### ASC Software

The Asynchronous Serial Communications (ASC) software controls the DTS hardware. It provides the interface between the IEEE 802.3 LAN and the MPE/iX operating system. The software is included with the MPE/iX Fundamental Operating System (FOS).

The MPE/iX system tracks all of the devices connected to it by means of configuration files. The network configuration information necessary to initialize and control the DTS resides in a special configuration file. This file is created through the Node Management Configuration Manager (NMMGR). *Configuring Systems for Terminals, Printers, and Other Serial Devices* provides a detailed discussion of the configuration process.

---

## Powerfail Recovery

DTC powerfail recovery works for direct-connect nailed sessions using character mode. The system also attempts to recover direct-connect sessions using block mode; however, this might not be successful if the powerfail has affected terminal configuration. This is especially true for VPLUS applications.

In the event of a DTC powerfail, some data loss might occur. Data buffered in the DTC at the time of the powerfail is not recoverable.

Upon system powerfail, the DTC retains sessions for approximately 20 minutes. This exceeds the duration of battery back-up on the system (15 minutes). Upon DTC powerfail, the system also retains sessions for about 20 minutes. If power is not restored before this time, sessions are aborted.

The terminal appears “hung” for approximately two minutes after power has been restored to the DTC (the time it takes for the DTC selftest and download to complete). Once the DTC is downloaded, there is a 10 second period for powerfail recovery of active sessions. During this time, the DTC will not respond to user input (pressing carriage return).

After this time, device control is restored. No “powerfail occurred” message is displayed. To confirm that device control has been restored, press **[Return]** until the colon prompt (:) is displayed.

In the event of a DTC powerfail, printer and modem connections as well as connections created via PAD and Telnet/iX are aborted.

## Troubleshooting Responsibilities

Many problems encountered with terminals and serial printers can be solved by the end user. Even more can be solved by a system manager. If the system manager cannot solve a problem, they should contact an HP support representative.

Each of the above groups has a specific role to play in the troubleshooting process. Each person needs to fulfill this role for troubleshooting to be completed quickly.

### Basic Troubleshooting

Troubleshooting usually begins with recognizing that the device is not working. The device might be “hung” (port not responding), transmission might be “garbled”, or the device might not work at all (screen or printer is “dead”). Record the following information to make troubleshooting easier:

- The ldev number of the device.
- The time that the problem began.
- The environment of the device when the problem occurred, including:
  - What application was running on the device.
  - Whether the device was in character or block mode (for terminals only).
  - What specific task was being attempted when the problem began.
- Symptoms of the problem and when each originated.
- Steps already taken to correct the problem.
- Whether the problem has occurred before.

### More Troubleshooting

A system manager has many troubleshooting responsibilities. They need to know how to collect information, analyze information, and (maybe most importantly) know when it is time to call an HP support representative. When an HP support representative is contacted, the system manager should have collected as much information as possible so that the HP representative has enough information to solve the problem or consult with other HP personnel.

A system manager should:

- Collect as much information as possible from the user.
- Check each device that is malfunctioning.
- Check configuration values for the malfunctioning devices.
- Perform a modem check (if modems are used).
- Run TermDSM to collect more information. At this point, it is usually possible to return specific devices or the whole subsystem to a state where new sessions can be started and new device opens can occur.

Not all of the above steps are necessary each time. For instance, if many devices go down at once, it is likely that the problem lies in the DTC or the LAN, instead of each individual device.

It is important to note that intermittent problems can become more frequent. This is especially true if a piece of hardware is beginning to fail.

If it is possible to reset the subsystem so that it appears to function normally, there is no reason to contact an HP support representative. However, it is important to keep an accurate log of the problems and to save any data you have accumulated from the problems. It might take data from several different occurrences of the problem to be able to pinpoint the area where the problem lies.

---

**CAUTION**

The system manager should not perform hardware diagnostics other than the loopback tests and the DTC selftest included in TermDSM. Only HP support representatives should perform other hardware diagnostics.

---

## **Hewlett-Packard Responsibilities**

It is ultimately Hewlett-Packard's responsibility to resolve problems that arise with the use of products that HP supports as specified in your customer service contract. The job of Hewlett-Packard personnel who are called to your site can be made more effective by the efforts of the users and the system manager. The more information the HP representative is given, the faster the problem can be solved.





Recall that, in this manual, “serial device” refers to any of the following DTC connected devices:

- Terminals.
- Serial printers.
- PCs (in terminal emulation mode).
- Plotters.

Serial device problems can be caused by the system, by application software, by faults within the device or DTC connections, or by the LAN hardware. Procedures for troubleshooting all possible faults are beyond the scope of this manual. Instead, the manual focuses on checking for simple faults at the device and testing the DTC and DTC-terminal connections.

## Troubleshooting Pathway

A practiced method for problem resolution is to first identify the problem and then identify alternative causes of that problem. Break the big problem into smaller, more manageable components. By breaking the problem into manageable and testable components, the cause can be easily isolated. A recommended troubleshooting pathway is shown in Figure e2-1.

Figure 2-1

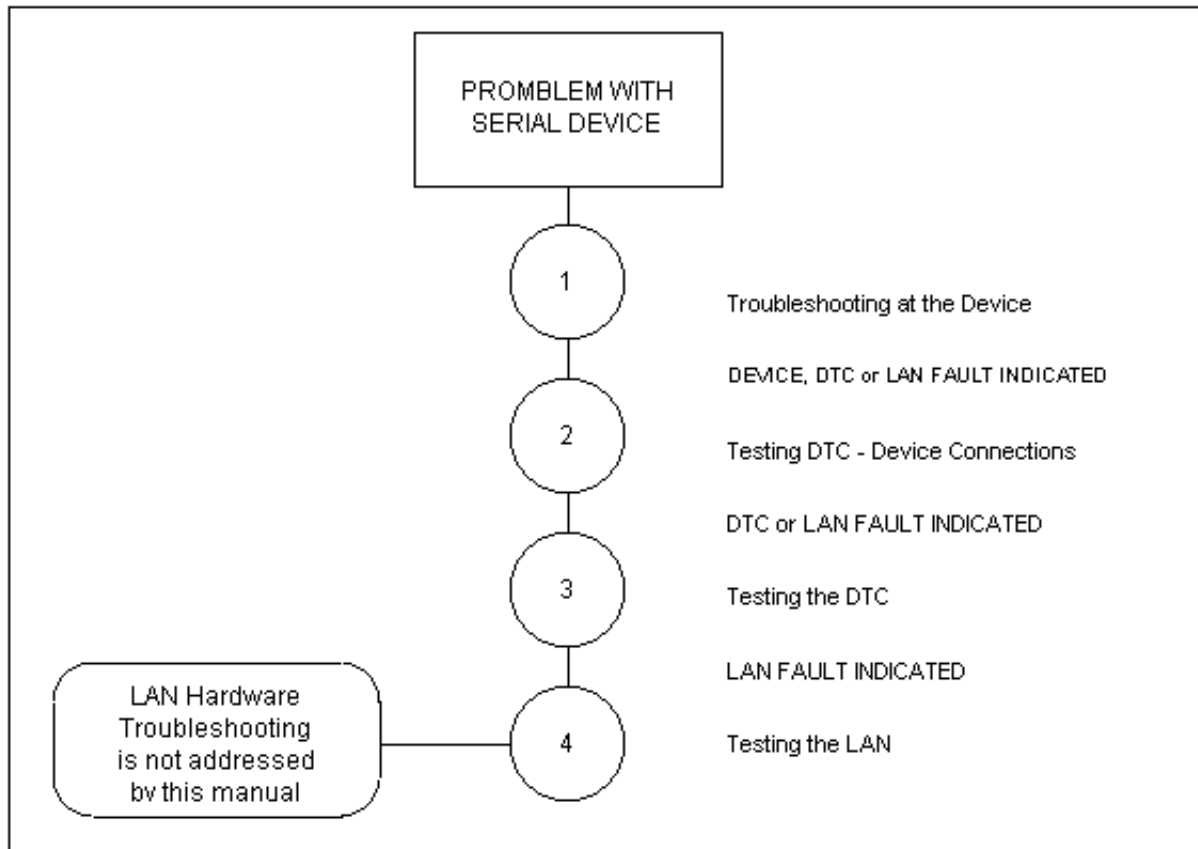

Each of the numbered circles is a task used to troubleshoot problems in networking environments. By completing these tasks, isolation of the cause of the problem is likely to occur; this is the most difficult part of troubleshooting. After the cause of the problem has been identified, take an appropriate action to resolve the problem. Each task is described below.

1. Troubleshooting at the Device. First, do some simple verifications at the device. This can rule out causes such as improper device settings and loose connections. Simple observations can also indicate if the problem is system-wide. The verifications require no particular expertise; they are appropriate for general users. After this, it will be clear if more detailed device, DTC, or LAN testing is needed.

2. Testing DTC-Device Connections. If necessary, use TermDSM for more detailed diagnostics. This must be done at another device or the console. Test DTC-device connections first. This can detect faults within the device, the device cable, and parts of the DTC circuitry. If DTC-device connections are not causing the problem, further DTC diagnostics are suggested.
3. Testing the DTC. Using TermDSM, perform a DTC selftest. The selftest can detect faults within specific field replaceable units (FRU) of the DTC. If the DTC passes the selftest, the fault might be in the LAN. Proceed with LAN diagnostics.
4. Testing the LAN. LAN troubleshooting is beyond the scope of this manual. It generally requires special tools and the expertise of an HP support representative.

Procedures to follow for the first three tasks in the troubleshooting pathway for host-based management are summarized in the following sections.

## Troubleshooting the Device

Most problems can be diagnosed and/or resolved quickly at the device (terminal or serial printer). It's best to do simple verifications before using TermDSM for more involved diagnostics. First, note the following:

- How many devices are affected?
- Which devices are affected?

The number and proximity of devices affected provides a clue to the cause. If all devices are affected, the fault is likely to be with the system. If several devices on a DTC are affected, the DTC is suspect. If all devices on a DTC are down, the DTC or LAN might be at fault.

If only one device is affected, the fault is likely in that device, the device cable, or the DTC components (hardware or software) that serve the device. If only one device is affected, verify that:

- The serial interface is connected.
- The power cord is connected and is powered on.

If the device is "hung" (the port is not responding), do the following:

- Press **[CONTROL]-Q**.
- Check that the device is in remote mode.
- Attempt a soft reset. Press **[SHIFT]-Reset**.
- Attempt a hard reset. Press **[CTRL]-Reset**.

If the device is not hung, but transmission or reception is "garbled", check that speed and parity sensing is enabled. Also check that the XON/XOFF protocol is enabled. If the user cannot logon, check that the device is configured correctly.

---

## Testing DTC Device Connections

This section applies if only one device is affected and simple causes have been ruled out. In this case, it is appropriate to use TermDSM for more detailed diagnostics. This must be done from another terminal or the console.

TermDSM is part of the Online Diagnostic Subsystem. The diagnostics in this section require security level 2 (SM, DI, or OP capability). For details on running TermDSM, refer to Chapter 3, “Introduction to TermDSM,” and Chapter 4, “TermDSM Commands.”

TermDSM provides four tests to exercise the DTC device data path. In addition, TermDSM provides dump and reset functions for the port serving that device.

A port dump writes data to a disk file from port buffers. The dump file can be analyzed by an HP representative for detailed diagnosis of software faults. A port reset terminates the session at that port and resets the software managers controlling it.

---

### NOTE

Always dump a port before resetting it or performing diagnostic tests. The dump file provides a record of the problem which will be helpful if the problem occurs again.

Using TermDSM, you can quickly isolate a fault to within the DTC, the device, or the device cable. The four DTC-device connection tests are:

- **Internal Port Loopback Test.** Tests the DTC serial interface card (SIC) circuitry for the port that serves the affected device. Additional hardware is not required; the affected device can remain connected.
- **External Port Loopback Test (for DTC 16s and DTC 48s only).** Checks the same circuitry, plus the driver, and the DTC connector for that port. The device is disconnected for this test; a loopback connector is required. Use the loopback connector provided with the DTC for the test.
- **Terminal Write/Read Test.** Checks the entire DTC device connection. This includes the SIC circuitry, the driver, the DTC connector, the device cable, and part of the device circuitry. TermDSM writes a line of characters to the device, then reads it back, comparing the two. The affected device remains connected. *This test is useful for only supported terminals and PCs.*
- **Print-to-Port Test.** This test is similar to the Terminal Write/Read Test. However, the character string is transmitted only (not read back by TermDSM). The user must check visually that the string received at the affected device is the same as was sent. The test is available for all devices.

Your choice of test will depend on:

- The type of device you are testing (supported or unsupported; terminal or printer).
- The availability of the appropriate loopback connector.

The tests can be used individually, or they can be used together to systematically isolate the fault. If used together, the following are recommended test sequences. For details on these tests, refer to Chapter 3, “Introduction to TermDSM,” and Chapter 4, “TermDSM Commands.”

The test sequence to use for supported devices is as follows:

1. Internal Port Loopback Test.

- If the test fails, the fault is in the DTC (refer to “Testing the DTC” later in this chapter).
  - If the test passes, do the Terminal Write/Read Test.
2. Terminal Write/Read Test.
    - If the test fails, and a loopback connector is available, do the External Port Loopback Test.
    - If the test fails, but no loopback connector is available, alternate testing is required (fault might be in the DTC, the device, or the device cable).
    - If the test passes, the fault is in the software.
  3. External Port Loopback Test.
    - If the test fails, the fault is in the DTC (refer to “Testing the DTC” later in this chapter).
    - If the test passes, the fault is in the device cable or the device.

The test sequence to use for printers or unsupported devices is as follows:

1. Internal Port Loopback Test.
  - If the test fails, the fault is in the DTC (refer to “Testing the DTC” later in this chapter).
  - If the test passes, but no loopback connector is available, alternate testing is required (fault might be in the DTC, the device, or the device cable).
  - If the test passes, and a loopback connector is available, do the External Port Loopback Test.
2. External Port Loopback Test.
  - If the test fails, the fault is in the DTC (refer to “Testing the DTC” later in this chapter).
  - If the test passes, do the Print-to-Port Test.
3. Print-to-Port Test.
  - If the test fails, the fault is in the device or the device cable.
  - If the test passes, the fault is in the inbound data path of the device or in the device cable.

---

## Testing the DTC

If the DTC is suspected as the cause, TermDSM can be used to determine the hardware or software component involved. It also provides DTC dump and reset functions.

---

### CAUTION

TermDSM functions described in this section cause all sessions on the DTC to abort. Data for each session can be lost. Verify that users are logged off before attempting these tests.

Security level 1 (SM or DI capability) is required for the following functions. For details on using TermDSM, refer to Chapter 3, “Introduction to TermDSM,” and Chapter 4, “TermDSM Commands.”

The `DUMP DTC` command writes data to a disk file from the software managers serving all the ports on the DTC. The dump file can be read by an HP support representative for detailed diagnosis of software faults. After the dump, the DTC selftest is run automatically.

The DTC selftest exercises the following: the DTC processor card, the serial interface cards, and the connector cards. The selftest runs for about 2 minutes. After the selftest, the DTC is downloaded and reset automatically. If you are running TermDSM at the console, messages will be displayed informing you of the download.

The selftest isolates faults within Field Replaceable Units (FRU) in the DTC. The faults are indicated by TermDSM messages and by error codes shown on the DTC's LED display. For information on servicing FRUs and reading DTC error codes, refer to the appropriate DTC Installation and Service Manual for your type of DTC.

## Testing the LAN

If system, device, and DTC faults are ruled out as the cause of the problem, LAN hardware is suspect. LAN hardware troubleshooting is beyond the scope of this manual. Contact your HP support representative.



TermDSM (Terminal Online Diagnostic/Support Monitor) is a utility program for host-based management that provides various diagnostic services for terminal and serial printer connections on systems of the HP 3000 Series 900 computer family. It is patterned after the MPE V utility of the same name. Typically, TermDSM is used when a problem is suspected with one or more terminals, printers, or other serial devices; the problem can be related to hardware or software.

The purpose of TermDSM is to gather information on software problems and isolate and correct problems with the hardware. TermDSM can also be used to test hardware connections between devices and the DTC. The primary difference between MPE V TermDSM and MPE/iX TermDSM results from the different hardware used between the two families of HP 3000 computers.

---

## TermDSM Requirements

The following hardware is required when using TermDSM:

- The minimal mainframe configuration of a HP 3000 Series 900 computer.
- The system and each DTC connected and configured as nodes on the LAN.
- At least one pair of serial interface/connector cards installed in each DTC, with at least one port of each connector card connected to an asynchronous device.
- The following loopback connectors supplied with each DTC (for DTC 16 and DTC 48 only):
  - 25-pin connectors for SNP cards (24400-60216)
  - 25-pin connectors for modem cards (02345-60010)
  - 3-pin connectors for RS-232-C direct-connect cards (30148-60002)
  - 5-pin connectors for RS-422 direct-connect cards (30147-60002)

The software required to use TermDSM is included with the MPE/iX operating system. The MPE/iX operating system must be functioning properly for TermDSM to work.

## User Capabilities and Security Levels

The functions of TermDSM commands are restricted by three different security levels. Each security level is associated with the capabilities necessary to use commands of that level. The security levels correspond to the Online Diagnostic Subsystem.

Table 3-1 lists the security levels and the corresponding capabilities. When a user issues a command, TermDSM checks the user's capability list to verify that the user is authorized to use commands of that security level. If the capabilities of the user are insufficient, the command is not executed and an error message is displayed on the terminal.

**Table 3-1** Security Levels for TermDSM

| Necessary User Capabilities | TermDSM and SYSDIAG Security Levels |
|-----------------------------|-------------------------------------|
| SM                          | 0                                   |
| SM or DI                    | 1                                   |
| SM or DI or OP              | 2                                   |

---

**NOTE** Users without any of the above capabilities cannot use TermDSM.

## A Word of Caution

Some TermDSM commands abort sessions and can cause a loss of data. If used incorrectly, the commands can unnecessarily disrupt or abort user sessions.

If more than one user is running TermDSM, it is not advisable for one user of TermDSM to reset another user of TermDSM. (The user's port, ldev, SIC, or DTC should not be reset.)

## TermDSM Functionality

TermDSM is a command-based utility program which allows you to monitor and troubleshoot the DTS. It is set up so that you can monitor the condition of a single device or an entire DTC.

TermDSM provides several specific functions. Some commands provide only information, such as a listing of all the DTCs associated with the system or the internal configuration information of any DTC. If problems are suspected, TermDSM can be used to test any DTC and its connections to devices.

If a problem is complex enough that the state of the port and/or the DTC subsystem needs to be looked at by an HP support representative, the subsystem information can be copied to a disk file and sent to Hewlett-Packard.

If it is determined that a device's connection is unusable, TermDSM is capable of aborting the session on the port so that a new session can be started on the device. This is also true if the connections of several devices are unusable or if all of the connections of the devices of a DTC are unusable.

---

## TermDSM Command Summary

This section lists the first level commands and basic functionality of all the available TermDSM operations. These commands are used to view, control and diagnose various operations of the DTS Subsystem.

- **C[onnect]** Access the Show Connections function to display all the TIO and PAD connections established through selected cards in the DTCs. The security level of this command is 2..
- **DI[AG]** Access the Diagnostic functions that can be run on a port. This command also accesses the function used to initiate a DTC selftest. The security level of this command is 1 for the DTC selftest, and 2 for the individual port tests.
- **DT[C]** Display a list of all the DTCs managed by this system along with its descriptive name and the IEEE 802.3 station address. The security level of this command is 2.
- **DU[MP]** Access the functions to copy a selected data area of a DTC or Ldev to a disk file for troubleshooting used by HP factory personnel. The security level of this command is 2. The data area copied to a disk file can be of a port, an ldev, an entire asynchronous processor board of a DTC 72MX or an entire DTC. The security level of this command is 1.
- **EE[PROM] DT[C]** Access the function used to download the new ROM code on the DTC 72MX and DTC 16iX/16MX. The security level of this command is 1.
- **EX[IT]** This command will exit the TermDSM program and return to the DUI prompt. The security level of this command is 2.
- **H[ELP]** This command displays information describing TermDSM and its command syntax. The security level of this command is 2.
- **M[ULTI]** Access the Multiple DTC operations function. This function allows you to perform a Start or Stop operation of the X.25 and PAD protocols on multiple X.25 cards in multiple DTCs with one command. The security level of this command is 1.
- **R[ESET]** Access the function that is used to reset a port, a board, a single DTC, or multiple DTCs to accept new sessions. The security level of resetting ports is 2, and the security level of resetting DTCs is 1.
- **S[TATUS]** Access the function that is used to display status information on a DTC, port, or X.25 card and PAD or Virtual Connections. The security level of this command is 2.
- **T[RACE]** Access the function that is used to enable or disable tracing for a port on an asynchronous processor board of a DTC 72MX or a DTC/X.25 Network Access card. Options allow trace to be activated for level 2, level 3, or a specific VC of the DTC/X.25 card. The security level of this command is 2.
- **X[25SITE]** Access the X.25 Site Management function that displays information on X.25 system-to-system connections between MPE/iX systems. The connection information covers three areas: information on all the DTCs managed by the system; information on the link for a particular DTC and the PSN; information on a specific connection. The security level of this command is 2.

Further explanation for each command is contained in Chapter 4, “TermDSM Commands.”

## Starting TermDSM

To use TermDSM, enter the SYSDIAG command at the MPE/iX prompt (:). The Diagnostic User Interface prompt appears:

```
DUI>
```

From this prompt, many diagnostics can be run. Type HELP to see a list. To run TermDSM, enter:

```
DUI>RUN TERMDSM
```

The following is an example of the type of information that will appear on the terminal:

```
*****
*****          TERMDSM          *****
*****
*****          *****
***** (C) Copyright Hewlett-Packard Co. *****
*****          *****
*****          1987, 1990, 1993 *****
*****          *****
*****          All Rights Reserved. *****
*****          *****
*****          *****
*****          Version C.00.40 *****
*****          *****
*****          *****
***** HP shall not be liable for any damages *****
***** resulting from the use of this program. *****
*****          *****
*****          *****
*****          Catalog AM.050 *****
*****          *****
*****          *****
```

Welcome, Today is THU, NOV 6, 2003 at 6:16 PM

Your system has these Datacommunications and Terminal Controllers:

| DTC    | Network      |               |
|--------|--------------|---------------|
| Number | Address      | Name          |
| -----  | -----        | ----          |
| 1      | 08000900180A | BIOLAB        |
| 2      | 080009001808 | MARKETING     |
| 3      | 080009001234 | TIMESHAREROOM |
| ^      |              |               |

Use this number as the "DTC number" in Termdsm commands.

```
Connect DIag DTC DUmp EEprom Help Multi Reset Status Trace X25site EXit?
```

The last line is the TermDSM prompt. Notice that the prompt lists all the possible commands that you can enter. The capital letters listed are the abbreviations for each command. You can stop the looping of a diagnostic function by entering [CTRL]-Y (looping is terminated after the current loop is completed).

## Stopping TermDSM

To stop using TermDSM, enter the `EXIT` command at the TermDSM main prompt. The `DUI` prompt is displayed. Enter `EXIT` again to return to the MPE/iX prompt.



This chapter provides complete descriptions of the TermDSM commands. Commands are listed in alphabetical order for your convenience. Each command description uses the same format:

1. Command Name.
2. Purpose of Command.
3. Security Level.
4. Syntax of the command's functions.
5. Parameter descriptions (if the command has parameters).
6. Description. This provides an explanation of the command's functions and details not listed in the individual parameter descriptions.
7. Subcommands (if the command has subcommands). Subcommand descriptions are in the same format as command descriptions: the subcommand's purpose, security level, syntax, and parameters are all listed, followed by a discussion.

## CONNECTION

This command accesses the subsection that displays information about the connections currently active on a specified DTC board.

Security level: 2.

### Syntax

C[onnection]

### Description

After the Connect command is entered, the following prompt is displayed on the terminal:

```
(show connection)
SHow #,#
(carriage return to exit)  ?
```

If you press **[Return]** instead of the subcommand, you will be returned to the major prompt and can then enter another TermDSM command.

## SHOW

This command displays information about the connections currently active on a specified DTC and card. The information displayed is formatted according to the type of connection and the type of board.

Security level: 2

### Syntax

SH[ow] *dicnum.cardnum*

### Parameters

|                |  |
|----------------|--|
| <i>dicnum</i>  | The number TermDSM associates with a particular DTC. The DTC command lists each DTC with its assigned number. This list is also printed when you enter an invalid number for a DTC number. |
| <i>cardnum</i> | Number of the interface card within the DTC to which the connection list is displayed. The cards are numbered from zero beginning at the bottom of the DTC.                                |

### Description

The three basic types of information are given.

- Information on the source. For example, the DTC board and port the device is connected to, or the X.25 address of the device initiating the connection.
- Information on the destination. For example, the destination nodename, or the DTC board and port the destination is connected to.

- Information on the connection. For example, the virtual circuit number or the AFCP connection number.

After the header in addition to the card and port number of the source DTC, the command displays the following information for the three type of connections possible through the Asynchronous Serial Card .

|                     |   |
|---------------------|---|
| To a MPE/iX host    | Destination node name, Ldev, AFCP connection number               |
| To an ARPA node:    | Destination IP address, TCP port number                           |
| To a DTC Host port: | Destination DTC node name, board, card; TCP Cnx number; Port name |

If the card is an X.25 card, the command displays the following information for the three types of PAD connections possible through the card.

|                     |  |
|---------------------|--|
| To a MPE/iX host    | Remote X25 addr; LCI #; Destination node name; VC type; Virtual port; Ldev #; AFCP Cnx#                          |
| To an ARPA node:    | Remote X25 addr; LCI #; Destination IP addr; VC type; Virtual Port number; TCP port number                       |
| To a DTC Host port: | Remote X25 addr; LCI #; Destination DTC Node Name; VC type; Virtual port #; DTC Brd#, Port#; TCP CNX#; Port Name |

**[CTRL]-Y** can be used during execution of the above subcommands to stop the output.

This is an example of the information displayed for connections from a DTC port to a MPE/iX host.

```
(carriage return to exit) ?sh 2 1
Board 1 is a SIC board, and has 2 connections.
-----
Board# Port# Destination
Information:
=====
      1      0 CSYPREL10.ITG.HP
Ldev# 300, AFCP CNX#      8
-----
      1      1 CSYPREL10.ITG.HP
Ldev# 301, AFCP CNX#      9
-----
```

This is an example of the information displayed for connections from a DTC port to a system that supports ARPA services.

```
      1      2 194.1.1.108
TCP Port# 23, MPX Session Number# 1
-----
      1      3 194.1.1.108
TCP Port# 23, MPX Session Number# 1
```

**CONNECTION**

-----  
This is an example of the information displayed for connections from a DTC port to another DTC Host port.

```
      1      4 WAR3.ITG.HP  
Board# 1, Port#    16, TCP CNX#12567, Port Name HOSTPORT
```

```
-----  
      1      5 WAR3.ITG.HP  
Board# 1, Port#    17, TCP CNX#12823, Port Name HOSTPORT
```

---

## DI[AG]

Determines if the DTC hardware or the connections from a DTC to its devices are functioning properly.

Security level: 1 for DTC selftest; 2 for remaining diagnostic functions.

### Syntax

DI[AG]

### Description

After the DIAG command is entered, the following prompt is printed on the terminal:

```
(diagnostics)
```

```
SElftest #      (DTC Selftest)
PRint   #,#,# (Print to specified port)
Internal #,#,# (Internal loopback on specified port)
EXTernal #,#,# (Loopback through hood on specified port)
Terminal #,#,# (Write and read to terminal on that port)
XInternal#,#, (Internal loopback on specified SNP card)
XExternal#,# (Loopback through hood on specified SNP card)
XNetwork #,#,# (Loopback on the highest and lowest VC)
```

```
(carriage return to exit) ?
```

These are the subcommands that can then be entered. The following pages describe each of these options.

If you press **[Return]** instead of one of the subcommands, you will be returned to the major prompt and can then enter another TermDSM command.

**[CTRL]-Y** can be used during execution of any of the above subcommands to stop the diagnostic looping. However, the current loop will always complete before the **[CTRL]-Y** takes effect. In the case of the DTC selftest, this can take several minutes.

## DI[AG] EXT[ERNAL]

Determines if a specific port is functioning properly, including the connector. Sends data out and reads it immediately, verifying that the data received is exactly what was sent. DIAG EXTERNAL is available for DTC 16s and DTC 48s only.

Security level: 2.

### Syntax

EXT[ERNAL] *dtcnum, cardnum, portnum*

**Parameters**

|                |   |
|----------------|---|
| <i>dtcnum</i>  | The number TermDSM associates with a particular DTC. The DTC command lists each DTC with its assigned number. This list is also printed when you make a mistake while typing in a DTC number. |
| <i>cardnum</i> | Number of the interface card within the DTC to which the device is connected. The cards are numbered from zero beginning at the bottom of the DTC.  |
| <i>portnum</i> | Number of the port on the interface card. As you face the back of the DTC, the ports are numbered from zero beginning at the left of the board.   |

**Description**

When this subcommand is entered, the following question is displayed on the terminal:

```
Do you want to stop looping if an error is found (yes/no)?
```

If the answer is yes, the series of loopback tests will stop if an error is encountered. For example, you specified you want the loopback test to run 10 times and an error is encountered in the third test. If you answered yes to the above question, the remaining seven tests will not be run. If you answered no, all 10 loopback tests will be executed regardless of the results of each test. The following is then printed on the terminal:

```
Please put a loopback hood on the Port, before answering
the "How many times?" question. (TDSM 113)
```

```
How many times do you want to repeat this operation?
```

At this time, go to the DTC and connect a loopback hood to the port. Then return and enter how many times you want to run this diagnostic function. Enter a number between 1 and 65535. The following is then displayed:

```
Type CONTROL_Y to stop the looping.
```

Any time that you want to stop the diagnostic, press **[CTRL]-Y**. The diagnostics prompt will be printed and you will be allowed to enter another subcommand.

If TermDSM knows that this test has failed, an error message will be printed listing the reason for the failure and how many milliseconds the test ran before failing.

The diagnostics prompt will be printed and you will be allowed to enter another subcommand.

**DI[AG] I[NTERNAL]**

Determines if a specific port is functioning properly without disconnecting the device from the port.

Security level: 2.

**Syntax**

```
I [INTERNAL] dtcnum, cardnum, portnum
```

## Parameters

|                |   |
|----------------|---|
| <i>dtnum</i>   | The number TermDSM associates with a particular DTC. The DTC command lists each DTC with its assigned number. This list is also printed when you make a mistake while typing in a DTC number. |
| <i>cardnum</i> | Number of the interface card within the DTC to which the device is connected. The cards are numbered from zero beginning at the bottom of the DTC.  |
| <i>portnum</i> | Number of the port on the interface card. As you face the back of the DTC, the ports are numbered from zero beginning at the left of the board.   |

## Description

This diagnostic cannot test all the functions that are possible with a **hood** (loopback connector), since the DTC connection itself cannot be tested without a hood. However, this diagnostic has the advantage that no cables need to be disconnected from or additional equipment connected to the port.

When the subcommand is entered you will be asked:

```
Do you want to stop looping if an error is found (yes/no)?
```

If you answer yes, the series of loopback tests will stop if an error is encountered. For example, you specified you want the test to run 10 times and an error is encountered in the third test. If you answered yes to the above question, the remaining seven loopback tests will not be run. If you answered no, all 10 loopback tests will be executed regardless of the results of each test. The following question is then printed on the terminal:

```
How many times so you want to repeat this operation?
```

You should then enter how many times you want to run this diagnostic function. Enter a number between 1 and 65535. The following is then displayed:

```
Type CONTROL_Y to stop the looping.
```

Any time that you want to stop the diagnostic, press **[CTRL]-Y**. The diagnostics prompt will be printed and you will be allowed to enter another subcommand.

If TermDSM knows that this test has failed, an error message will be printed listing the reason for the failure and how many milliseconds the test ran before failing.

The diagnostics prompt will be printed and you will be allowed to enter another subcommand.

## DI[AG] PR[INT]

Determines if the connection between a DTC and one of its devices is functioning properly by printing to the device.

Security level: 2.

## Syntax

```
PR[INT] dtnum, cardnum, portnum
```

**Parameters**

|                |   |
|----------------|---|
| <i>dtnum</i>   | The number TermDSM associates with a particular DTC. The DTC command lists each DTC with its assigned number. This list is also printed when you make a mistake while typing in a DTC number. |
| <i>cardnum</i> | Number of the interface card within the DTC to which the device is connected. The cards are numbered from zero beginning at the bottom of the DTC.  |
| <i>portnum</i> | Number of the port on the interface card. As you face the back of the DTC, the ports are numbered from zero beginning at the left of the board.   |

**CAUTION**

This subcommand aborts the session at the terminal under test. Data for that session is lost.

**Description**

This diagnostic is supplied primarily for use with devices that do not support loopback tests, such as serial printers, or unsupported terminals.

When the subcommand is entered you will be asked:

```
Do you want to stop looping if an error is found (yes/no)?
```

If you answer yes, the series of print operations will stop if an error is encountered. For example, you specified you want the test to run 10 times and an error is encountered in the third printing. If you answered yes to this last question, the remaining seven tests will not be run. If you answered no, all 10 print operations will be executed regardless of the results of each test. The following is then printed on the terminal:

```
Please connect and make ready (power on, remote mode, etc.) a
supported printer (or terminal), before answering the "How many
times?" message. (TDSM 115)
```

```
How many times do you want to repeat this operation?
```

You should then enter how many times you want to run the print operation. Enter a number between 1 and 65535. Then the following is displayed:

```
Type CONTROL_Y to stop the looping.
```

Any time that you want to stop the diagnostic, press **[CTRL]-Y**. The diagnostics prompt will be printed and you will be allowed to enter another subcommand.

The Print subcommand sends the following string of characters to the device:

```
JKLMNOPQRSTUVWXYZ[\]^_'abcdefghijklmnopqrstuvwxy
```

If TermDSM knows that this test has failed, an error message will be printed listing the reason for the failure and how many milliseconds the test ran before failing.

**NOTE**

If the test passes according to TermDSM, then it is your responsibility to inspect the output of the test to see if it matches the string of characters listed above. TermDSM cannot know the final outcome of the test; therefore, the only way to be sure that the test was successful is through visual inspection.

The diagnostics prompt will be printed on the terminal in order to allow you to enter another subcommand.



## DI[AG] SE[LFTEST]

Determines if the hardware of a particular DTC is functioning properly.

Security level: 1.

### Syntax

```
SE[LFTEST] dtnum
```

### Parameter

*dtnum*            The number TermDSM associates with a particular DTC. The DTC command lists each DTC with its assigned number. This list is also printed when you make a mistake while typing in a DTC number.

---

### CAUTION

---

This subcommand aborts all sessions on the DTC under test. Data for those sessions may be lost.

### Description

After entering the `Selftest` subcommand, the following is printed on the terminal:

```
Warning: This will rest all users on that DTC. (TDSM 44)
Do you want to continue (yes/no)?
```

If you answer no to this question, you will be returned to the diagnostics prompt. If you answer yes, the following will be printed on the terminal:

```
How many times do you want to repeat this operation?
```

You should then enter how many times you want to run the DTC selftest. Enter a number between 1 and 65535. The following question is then printed on the terminal:

```
Do you want to stop looping if an error is found (yes/no)?
```

If you answer yes, the series of selftests will stop if an error is encountered. For example, you specified you want the selftest to run 10 times and an error is encountered in the third selftest. If you answered yes to this last question, the remaining seven selftests will not be run. If you answered no, all 10 selftests will be executed regardless of the results of each test. The following is then printed on the terminal:

```
Each DTC self test can take several minutes. Enter a control-y
to stop the self test loop (the control-y will take effect when
the current self test finishes).
```

Anytime that you want to stop the diagnostic, press **[CTRL]-Y**. After the current loop has executed, the diagnostics prompt will appear and you may enter another subcommand.

The `Selftest` subcommand causes a complete DTC selftest to be run. This selftest includes the selftests for each of the interface cards within the DTC, and a download of the DTC across the LAN. Any jobs or sessions that are running on devices connected to the DTC are aborted.

---

### NOTE

---

Each loop of the `Selftest` subcommand is functionally identical to the `RESET DTC` subcommand. The inclusion of both commands is for your convenience, and to provide looping capability in the event an intermittent hardware failure is suspected.

As each selftest completes, the results of each SIC selftest will be printed on the terminal. Below is a selftest print out for a DTC 48:

| Card | SIC/SNP type      | Card test status | Ports (G:good or x:bad) |
|------|-------------------|------------------|-------------------------|
| 5    | (not installed)   |                  |                         |
| 4    | (not installed)   |                  |                         |
| 3    | X25 RS-232 Direct | OK               | GG                      |
| 2    | TIO RS-232 Direct | OK               | GGGG GGGG               |
| 1    | TIO RS-232 Direct | OK               | GGGG GGGG               |
| 0    | TIO RS-232 Modem  | OK               | GGGG GG                 |

The test passed 1 times and failed 0 times.

After all selftests complete, the DTC software is downloaded to the DTC so that users can again use devices connected to the DTC. You will receive messages to inform you of each download if you are running TermDSM from the console. You will then be returned to the diagnostics prompt.

## DI[AG] T[ERMINAL]

Determines if the connection between a DTC port and a terminal is functioning properly. TermDSM writes a line of characters to the terminal and orders it to send that line back. TermDSM then compares the characters received with those sent.

Security level: 2.

### Syntax

T[ERMINAL] *dtcnum, cardnum, portnum*

### Parameters

|                |   |
|----------------|---|
| <i>dtcnum</i>  | The number TermDSM associates with a particular DTC. The DTC command lists each DTC with its assigned number. This list is also printed when you make a mistake while typing in a DTC number. |
| <i>cardnum</i> | Number of the interface card within the DTC to which the device is connected. The cards are numbered from zero beginning at the bottom of the DTC.  |
| <i>portnum</i> | Number of the port on the interface card. As you face the back of the DTC, the ports are numbered from zero beginning at the left of the board.   |

### Description

When the subcommand is entered the following question is asked:

Do you want to stop looping if an error is found (yes/no)?

If you answer yes, the series of diagnostics will stop if an error is encountered. For example, you specified you want the write/read operation to run 10 times and an error is encountered in the third test. If you answered yes to the above question, the remaining

seven write/read operations will not be run. If you answered no, all 10 write/read operations will be executed regardless of the results of each test. The following is then printed on the terminal:

```
Please connect and make ready (power on, remote mode, etc.)
a supported terminal, before answering the "How many times?"
question. (TDSM 114)
```

```
How many times do you want to repeat this operation?
```

You should prepare the terminal and then enter how many times you want to run this diagnostic function. Enter a number between 1 and 65535. The following is then displayed:

```
Type CONTROL_Y to stop the looping.
```

Any time that you want to stop the diagnostic, press **[CTRL]-Y**. The diagnostics prompt will be printed and you will be allowed to enter another subcommand.

This diagnostic function tests the connection between the DTC port up to and including some terminal functions. (It is not a thorough terminal test.) It does this by writing a string of characters to the terminal and ordering the terminal to send those characters back for comparison. The string of characters sent by TermDSM is preceded by:

**[ESC]-H [ESC]-J**

which homes the cursor on the screen and clears the screen. Then the character string:

```
ABCDEFGHIJKLMNOPQRSTUVWXYZ[\]^_`abcdefghijklmnopqrstuvwxyz
```

is written to the terminal, followed by:

**[ESC]-H [ESC]-D**

which homes the cursor and causes the terminal to return the character string. (Sending **[ESC]-D** to the terminal is the same as pressing **[Return]**.)

If TermDSM knows that this test has failed, an error message will be printed listing the reason for the failure and how many milliseconds the test ran before failing.

The diagnostics prompt will be printed and you will be allowed to enter another subcommand.

## DI[AG] XI[NTERNAL]

Determines if the SNP hardware is functioning properly. The internal loopback test is executed only if the SNP is not started. No external connections are required.

Security level: 2.

### Syntax

```
XI [NTERNAL] dtnum, cardnum
```

### Parameters

*dtnum*                   The number TermDSM associates with a particular DTC. The DTC command lists each DTC with its assigned number. This list is also printed when you make a mistake while typing in a DTC number.

*cardnum*            Number of the interface card within the DTC to which the device is connected. The cards are numbered from zero beginning at the bottom of the DTC. (Note that SNP cards may not be mounted in slot 0 or 1 for DTC 16, and slot 0 for DTC 48.)

### Description

Determines if the SNP hardware is functioning properly. This internal loopback test is executed only if X.25 is not started on this SNP (X25 Level 1, 2, and 3). No external connections are required.

All loopback tests are disruptive in the sense they will abort any existing VC connections on that SNP. Other SNPs in the DTC will not be effected.

When the subcommand is entered the following question is asked:

```
Do you want to stop looping if an error is found (yes/no)?
```

If you answer yes, the loopback tests will stop if an error is encountered. The following is then printed on the terminal:

```
How many times do you want to repeat this operation?
```

Enter the number of times you want to run this diagnostic function. Enter a number between 1 and 65535. The following is then printed on the terminal:

```
Type CONTROL - Y to stop the looping.
```

You can use subsystem break (normally **[CTRL]-Y** to stop the diagnostic at any time. The diagnostics prompt will be printed and you will be allowed to enter another subcommand.

If TermDSM knows that this test has failed, an error message will be printed listing the reason for the failure and how many milliseconds the test ran before failing. The diagnostics prompt will be printed and you will be allowed to enter another subcommand.

### DI[AG] XE[XTERNAL]

Determines if the SNP hardware and the physical connection is functioning properly. The external loopback test is executed only if the SNP is not started. External connections are required only for the V.35, the V.36, and the RS-422 interface. (External loopback is not available for the DTC 72MX.)

Security level: 2.

### Syntax

```
XE[XTERNAL] dtnum, cardnum
```

### Parameters

*dtnum*            The number TermDSM associates with a particular DTC. The DTC command lists each DTC with its assigned number. This list is also printed when you make a mistake while typing in a DTC number.

*cardnum*            Number of the interface card within the DTC to which the device is connected. The cards are numbered from zero beginning at the bottom of the DTC. (Note that SNP cards may not be mounted in slot 0 or 1 for DTC 16, and slot 0 for DTC 48.)

## Description

Determines if the SNP hardware is functioning properly. This internal loopback test is executed only if the SNP is not started (X25 Level 1, 2, and 3). External connections are required only for the V.35, the V.36, and the RS-422 interface.

All loopback tests are disruptive in the sense they will abort any existing VC connections on that SNP. Other SNPs in the DTC will not be effected.

When the subcommand is entered the following question is asked:

```
Do you want to stop looping if an error is found (yes/no)?
```

If you answer yes, the loopback tests will stop if an error is encountered. The following is then printed on the terminal:

```
Please put a loopback hood on the port before answering the
"How many times?" question. (TDSM 113)
```

```
How many times do you want to repeat this operation?
```

Enter the number of times you want to run this diagnostic function. Enter a number between 1 and 65535. The following is then printed on the terminal:

```
Type CONTROL - Y to stop the looping.
```

You can use subsystem break (normally **[CTRL]-Y** to stop the diagnostic at any time. The diagnostics prompt will be printed and you will be allowed to enter another subcommand.

If TermDSM knows that this test has failed, an error message will be printed listing the reason for the failure and how many milliseconds the test ran before failing. The diagnostics prompt will be printed and you will be allowed to enter another subcommand.

## DI[AG] XN[ETWORK]

Determines if the connection to the network is functioning properly. This test is executed only if the SNP is not started.

Security level: 2.

### Syntax

```
XN[ETWORK] dtcnum, cardnum,
           destination address
```

### Parameters

|                            |   |
|----------------------------|---|
| <i>dtcnum</i>              | The number TermDSM associates with a particular DTC. The DTC command lists each DTC with its assigned number. This list is also printed when you make a mistake while typing in a DTC number.   |
| <i>cardnum</i>             | Number of the interface card within the DTC to which the device is connected. The cards are numbered from zero beginning at the bottom of the DTC. (Note that SNP cards may not be mounted in slot 0 or 1 for DTC 16, and slot 0 for DTC 48.) |
| <i>destination address</i> | The X.25 address. This address has a total of 15 digits.  |

### Description

Determines if the network is functioning properly by testing the connection between an SNP and the network. The test tries to send and receive data from the network. To do this, a VC is opened with a destination address on the local side. The correct X.25 address must be configured in the Level 3 Configuration screen in NMMGR. Additionally, this address must be entered as the last parameter of the SNP network loopback command. This test is executed only if X.25 is not started on this SNP (X25 Level 1, 2, and 3).

All loopback tests are disruptive in the sense they will abort any existing VC connections on that SNP. Other SNPs in the DTC will not be effected.

When the subcommand is entered the following question is asked:

```
Do you want to stop looping if an error is found (yes/no)?
```

If you answer yes, the loopback tests will stop if an error is encountered. The following is then printed on the terminal:

```
Please connect and make ready an X.25 network (power on, X.25 line  
correctly configured, etc.) connection to the SNP card, before  
answering the "How many times?" question.
```

```
How many times do you want to repeat this operation?
```

Enter the number of times you want to run this diagnostic function. Enter a number between 1 and 65535. The following is then printed on the terminal:

```
Type CONTROL - Y to stop the looping.
```

You can use subsystem break (normally **[CTRL]-Y** to stop the diagnostic at any time. The diagnostics prompt will be printed and you will be allowed to enter another subcommand.

If TermDSM knows that this test has failed, an error message will be printed listing the reason for the failure and how many milliseconds the test ran before failing. The diagnostics prompt will be printed and you will be allowed to enter another subcommand.

---

## DT[C]

Lists each DTC assigned to the system and displays the number that TermDSM has assigned to each DTC.

Security level: 2.

### Syntax

DT[C]

### Description

When this command is entered, information similar to the following is displayed on the terminal:

Your system has these Datacommunications Terminal Controllers:

| DTC<br>Number | Network Name<br>Address |               |
|---------------|-------------------------|---------------|
| -----         | -----                   | ----          |
| 1             | 08000900180A            | BIOLAB        |
| 2             | 080009000808            | MARKETING     |
| 3             | 080009001234            | TIMESHAREROOM |
| ^             |                         |               |

Use this number as the "DTC number" in TermDSM commands.

The DTC Node Name that was associated with each DTC at configuration time is displayed along with the IEEE 802.3 station address of each DTC. The number in the first column is assigned by TermDSM and these numbers must be used in other TermDSM commands to reference particular DTCs.

After the above display is printed, the major prompt will be printed and you may enter another TermDSM command.

If, during a TermDSM command, you make an error in specifying a DTC number, the above display is automatically printed to the terminal for your convenience.

---

#### NOTE

The listing of DTCs with an IEEE 802.3 station address and name is not a guarantee that each DTC exists, is installed, is powered on, or is otherwise functional. This information is obtained from the NMCONFIG.PUB.SYS file and is therefore only a reflection of what has been configured (correctly or otherwise).

---

---

## DU[MP]

Captures data pertaining to a particular port, asynchronous processor board (mux card of a DTC 72MX), DTC, or logical device number and writes it to a disk file.

Security level: 1 for DTC dump; 2 for remaining dump functions.

### Syntax

DU[MP]

### Description

After the Dump command is entered, the following prompt is printed on the terminal:

```
(dump)
```

```
Ldev #
Port #, #, #
SNP #, #
Mux #, #
Vc #, #, #
DTC #
```

```
(carriage return to exit) ?
```

These are the subcommands that can then be entered. The following pages describe each of these options.

If you press **[Return]** instead of one of the subcommands, you will be returned to the major prompt and may then enter another TermDSM command.

There are five different types of dump files:

- Information regarding a particular DTC. This information is written to a disk file in binary form.
- Information regarding a particular asynchronous processor board in a DTC 72MX.
- Information regarding a particular logical device number or physical port.
- Information regarding a particular SNP (X.25) card.
- Information regarding a particular virtual circuit on an X.25 card.

If you need the information in the dump analyzed, send it to your HP representative on magnetic tape.

Information written to a disk file for this type of dump will appear in two forms:

- A hexadecimal listing of all data.
- The ASCII representation of each byte of that data.



The file will also contain:

- The day and time of the dump.
- The type of dump (logical device number or port).
- Headings before each of the major areas of dump information.

If a dump file for an ldev number or port is to be printed, a printer file equation with the CCTL option should be used. In the following example, TRM123AB is the name of the dump file:

```
:FILE LIST;DEV=LP;CCTL
:PRINT TRM123AB.PUB.SYS,*LIST
```

---

**NOTE**

Complete information describing the situation that necessitated the use of DUMP is invaluable in assisting the HP representative's analysis of TermDSM dumps. You may use the COMMENT command to help document the situation.

---

## DU[MP] DT[C]

Captures data pertaining to a particular DTC and writes it to a disk file.

Security level: 1.

### Syntax

DT[C] *dtnum*

### Parameter

*dtnum*            The number TermDSM associated with a particular DTC. The DTC command lists each DTC with its assigned number. This list is also printed when you make a mistake while typing in a DTC number.

---

**CAUTION**

This subcommand resets all sessions on the DTC under test.

---

### Description

When this subcommand is entered, the following message will be printed on the terminal:

```
Warning: This will reset all users on that DTC. (TDSM 44)
Do you want to continue (yes or no)?
```

If you respond no, the DUMP prompt will be repeated for you to enter another DUMP subcommand. If you respond yes, the dump continues after the following message:

```
The DTC dump can take as long as 7 minutes .....
```

After the dump, a selftest is done on the DTC and status on each card is displayed.

The DTC dump information is placed in two files. The first file contains information about the part of the DTS software that resides on the host (the HP 3000). When the dump of this information is complete, the following information will be displayed:

```
The following two files make up the DTC dump. Please
deliver both to your HP representative: (TDSM 64)
```

**DU[MP]**

```
Shhhhhhc.PUB.SYS
```

```
TRMdddll.PUB.SYS
```

where *hhhhhh* is the last six hexadecimal digits of the DTC's LAN address and *c* is a character in the range from A to Z. The *ddd* is the Julian day of the year and *ll* is a two-character string in the range:

```
AA, AB, AC, ..., BA, BB, BC, ..., ZZ
```

This numbering system allows you to create many dump files in one day and to later know on what day each dump was created by simply looking at the file name.

If you need to send dump information to HP to have it analyzed, make sure that you send both dump files.

**NOTE**

If all 26 (suffix A through Z) DTC dump files already exist, one will be overwritten by the current DTC dump. If you are doing a lot of DTC dumps, you may wish to store off or rename some dump files to preserve them.

**DU[MP] LD[EV]**

Captures data pertaining to a specific logical device number and writes it to a disk file.

Security level: 2.

**Syntax**

```
LD[EV] ldevnum
```

**Parameter**

|                |   |
|----------------|---|
| <i>ldevnum</i> | The logical device number associated with the device whose data you want to dump. |
|----------------|---|

**Description**

Information associated with the logical device number is dumped to a disk file. Since the *ldev* is also associated with a port, information pertaining to the port is also dumped. Therefore, if you have identified a terminal problem and dump information using the *ldev* subcommand, complete information about the terminal connection is dumped; there is no need to also use the *PORT* subcommand.

**NOTE**

Dumping information pertaining to a logical device number does not reset (or otherwise affect) the associated device. If you need to reset the device, use the *RESET* command.

When the dump is complete, the following information will be displayed:

```
The dump file is TRMdddll.PUB.SYS
```

where *ddd* is the Julian day of the year and *ll* is a two-letter string in the range:

```
AA, AB, AC, ..., BA, BB, BC, ..., ZZ
```

This numbering system allows you to create many dump files in one day and to later know on what day each dump was created by simply looking at the file name.

The dump prompt is then repeated so that you may enter another dump subcommand.

## DU[MP] M[UX]

Captures data pertaining to a particular asynchronous processor board (mux card) of a DTC 72MX to a disk file. This command is supported for DTC 72MX only.

Security level: 2.

### Syntax

M[UX] *dtcnum, boardnum*

### Parameters

*dtcnum*            Number of the DTC to which the board is installed. This is the number TermDSM associates with this DTC.

*boardnum*        Number of the asynchronous processor board (mux card) within the DTC 72MX. The boards are numbered from zero beginning at the bottom of the DTC.

### Description

When this subcommand is entered, the following message will be printed on the terminal:

```
Warning: This will abort all users on that MUX. As many as
24 users will be affected. (TDM 49). Do you want to continue
(yes/no)?
```

If you respond no, the DUMP prompt will be repeated for you to enter another DUMP subcommand. If you respond yes, the dump continues. When the dump is complete, the following information will be displayed:

```
Please deliver the following MUX dump to your HP representative.

Mnhhhhhc.PUB.SYS
```

Where *n* is the board number within the DTC, *hhhhh* is the last five hexadecimal digit of the DTC's LAN address, and *c* is a character in the sequence a, b, ...z to allow multiple dumps.

## DU[MP] PO[RT]

Captures data pertaining to a particular port and writes it to a disk file.

Security level: 2.

### Syntax

PO[RT] *dtcnum, cardnum, portnum*

### Parameters

*dtcnum*            Number of the DTC to which the device is connected. This is the number TermDSM associates with this DTC.

*cardnum*         Number of the interface card within the DTC to which the device is connected. The cards are numbered from zero beginning at the bottom of the DTC.

*portnum*            Number of the port on the interface card. As you face the back of the DTC, the ports are numbered from zero beginning at the left of the board.

### Description

Information associated with the port is dumped to a disk file. If the port is also associated with an ldev number, information pertaining to the ldev number is dumped. If you have identified a terminal problem and dump information using the `PORT` subcommand, complete information about the terminal connection is dumped; there is no need to also use the ldev subcommand.

---

### NOTE

Dumping information pertaining to a port does not reset (or otherwise affect) the associated device. If you need to reset the device, use the `RESET` command.

When the dump is complete, the following information will be displayed:

```
The dump file is TRMdddll.PUB.SYS
```

where `ddd` is the Julian day of the year and `ll` is a two-character string in the range:

```
AA, AB, AC, ..., BA, BB, BC, ..., ZZ
```

This numbering system allows you to create many dump files in one day and to later know on what day each dump was created by simply looking at the file name.

## DU[MP] SN[P]

Captures data pertaining to a particular X.25 card and writes it to a disk file.

Security level: 2.

### Syntax

```
SN[P] dtnum, cardnum
```

### Parameters

*dtnum*            Number of the DTC that contains the SNP card (X.25 card). This is the number TermDSM associates with this DTC.

*cardnum*        Number of the interface card within the DTC. The cards are numbered from zero beginning at the bottom of the DTC. (Note that SNP cards may not be mounted in slots 0 or 1 for DTC 16, and slot 0 for DTC 48.)

### Description

Information associated with the X.25 card is dumped to a disk file. Complete SNP RAM will be dumped to the disk file. Because of this, all X.25 connections using the specified SNP card are aborted. The following message is displayed:

```
Warning: This will reset all users on that SNP. As many  
as 256 virtual circuit could be affected (TDSM 45).  
Do you want to continue (yes/no)?
```

If you respond no, the `DUMP` prompt will be repeated for you to enter another `DUMP` subcommand. If you respond yes, the dump continues.

When the dump is complete, the following information will be displayed:

Please deliver the following SNP dump to your HP representative.

```
Cbxxxxxa.PUB.SYS
```

where *b* is the board number in that DTC, *xxxxx* is the last 5 characters of the IEEE 802.3 address of that DTC and *a* is a character in the sequence a, b, ...,z to allow multiple dumps.

## DU[MP] V[C]

Captures data pertaining to a particular VC on an X.25 card and writes it to a disk file. (If the VC you are attempting to dump is a PAD VC, you must use the `Ldev` option instead.)

Security level: 2.

### Syntax

```
V[C] dtcnum, cardnum, vcnun
```

### Parameters

|                |   |
|----------------|---|
| <i>dtcnum</i>  | Number of the DTC that contains the SNP (X.25) card. This is the number TermDSM associates with this DTC.   |
| <i>cardnum</i> | Number of the X.25 card within the DTC. The cards are numbered from zero beginning at the bottom of the DTC. (Note that SNP cards may not be mounted in slot 0 or 1 for DTC 16, and slot 0 for DTC 48.) |
| <i>vcnum</i>   | Number of the VC on the X.25 card. (PAD VCs must be dumped using the <code>Ldev</code> option.)   |

### Description

Information associated with the VC on the X.25 card is dumped to a disk file.

---

#### NOTE

Dumping information pertaining to a VC does not reset (or otherwise affect) the associated device. If you need to reset the VC, use the `RESET` command.

---

When the dump is complete, the following information will be displayed:

Please deliver the following VC dump to your HP representative.

```
Vxxxxxxa.PUB.SYS
```

where *b* is the board number in that DTC, *xxxxx* is the last 5 characters of the IEEE 802.3 address of that DTC and *a* is a character in the sequence a, b, ...,z to allow multiple dumps.

## EE[PROM] DT[C]

Downloads the new ROM code on the DTC 72MX and DTC 16iX/16MX. This feature is not supported on the DTC 48 and the DTC 16.

Security level: 1.

### Syntax

DT[C] *dtcnum*

### Parameter

*dtcnum*            The number TermDSM associated with a particular DTC. The DTC command lists each DTC with its assigned number. This list is also printed when you make a mistake while typing in a DTC number.

---

#### CAUTION

This subcommand aborts all sessions on the DTC under test. All users on the DTC under test should be logged off prior to running this subcommand.

---

#### WARNING

**Do NOT power off the DTC until the EEPROM reprogramming is complete. Doing so will leave the DTC in an unusable state.**

### Description

When this subcommand and the correct ROM version (made up of 8 ASCII characters) are entered, the following message will be printed on the terminal:

```
TermDSM will now reprogram EEPROM with version XXXXXXXX.  
(TDSM 637) Do you want to continue (yes or no)?
```

If you respond no, you will be returned to the major command. If you respond yes, the following message will be displayed:

```
The EEPROM reprogramming process is executing. The process takes  
about 7-10 minutes.
```

```
Warning: Interrupting the process can be fatal to the DTC.
```

After the EEPROM reprogramming is completed, the following is printed on the terminal:

```
The EEPROM reprogramming was successfully completed. (TDSM 635)
```

---

## **EX[IT]**

Exits the TermDSM program and returns you to the DUI prompt. Security level: 2.

### **Syntax**

`EX[IT]`

## **H[ELP]**

Lists information regarding TermDSM and its commands.

Security level: 2.

### **Syntax**

H[ELP]



---

## MULTI

This command accesses the subcommands that allow you to start or stop the X.25 or PAD protocols on multiple DTCs and multiple X.25 cards.

Security level: 1.

### Syntax

M[ulti]

### Description

After the MULTI command is entered, the following prompt is printed on the terminal:

```
(multiple operations)
Current operation  NONE. Selected Modules X.25 [ ] PAD [ ]
START #,#         (X.25,PAD)
STOp  #,#         (X.25,PAD)
Dtc   #           List of DTCs
(carriage return to exit) ?
```

When the submenu is first displayed, the selected operation is NONE. You must first enter the START or STOP command and specify either 'Y' or 'N' for both protocols. Once the current operation is set, then enter the DTC command with the numbers of the desired DTCs. The three subcommands are described in the following sections.

### START or STOP

These subcommands select whether the operation to be performed on the DTC will be to start or stop the selected protocols.

#### Syntax

```
STAR[t] x25, pad
STO[p] x25, pad
```

#### Parameters

*x.25*            If this parameter is 'Y' then the X.25 protocol is selected, otherwise enter 'N' to unselect the protocol.

*pad*             If this parameter is 'Y' then the PAD protocol is selected, otherwise enter 'N' to unselect the protocol.

#### Description

After the START or STOP command is entered, the current operation changes to the one specified, and an 'X' is displayed for the selected protocols.

#### Example for Start operation:

```
(carriage return to exit) ?star y y
(multiple operations)
```

```

Current operation  START. Selected Modules X.25 [X] PAD [X]
START #,#          (X.25,PAD)
STOp #,#          (X.25,PAD)
Dtc #             List of DTCs
(carriage return to exit) ?dt 1,2

```

## DTC

After the operation and protocols are selected this command is used to initiate the operation on a set of selected DTCs.

### Syntax

```
D[tc] dtcnums
```

### Parameters

D[tc] The DTC number TermDSM associates with a particular DTC. The DTC command lists each DTC with its assigned DTC number.

You may specify multiple DTCs with one DTC command. The first command below sends the start or stop command to DTC 3, 5 and 9. The second command sends the start or stop command to DTCs 4 through 15 inclusive.

```

DTC 3, 5, 9
DTC 4/15

```

### Description

After the DTC command is entered, the operation will be attempted on all the selected cards and DTCs. The following is an example of the status display that is printed on the terminal.

#### Example for Start operation:

```

(carriage return to exit) ?dt 1,2
DTC  1 Board  2 :Start X.25 Successful, start PAD successful.
DTC  2 Board  2 :Start X.25 Successful, start PAD successful.
DTC  2 Board  3 :Start X.25 Successful, start PAD successful.
(multiple operations)
Current operation  START. Selected Modules X.25 [X] PAD [X]
START #,#          (X.25,PAD)
STOp #,#          (X.25,PAD)
Dtc #             List of DTCs
(carriage return to exit) ?

```

---

## R[ESET]

To clear hardware and software associated with a logical device number, physical port, serial interface card, or DTC so that a new session or job can be started on each port.

Security level: 1 for DTC; 2 for remaining functions.

### Syntax

```
R[ESET]
```

### Description

After the RESET command is entered, the following prompt is printed on the terminal:

```
(reset)

Ldev #
Port #,#,#
SNP #           ,(X.25 card in DTC)
Vc  #,#,#
SIC #           ,(multiplexer card in DTC)
DTC #

(carriage return to exit) ?
```

These are the subcommands that can then be entered. The following pages describe each of these options.

If you press **[Return]** instead of one of the subcommands, you will be returned to the major prompt and may then enter another TermDSM command.

Some port/ldev problems can not be fixed with ldev or port resets. If a port is still unusable after a reset, consider using RESET SIC. Note that this will affect all users on that card. Finally, if the RESET SIC is also unsuccessful, then the entire DTC should be reset. Note that this will affect all the users on the DTC.

## R[ESET] DT[C]

Resets the hardware of a particular DTC or group of DTCs.

Security level: 1.

### Syntax

```
DT[C] dtcnums
```

### Parameter

*dtcnums* The DTC number TermDSM associates with a particular DTC. The DTC command lists each DTC with its assigned DTC number.

**R[ESET]**

You may also reset multiple DTCs with one `RESET DTC` command. The first command below resets DTC 3, 5, and 9. The second command resets DTCs 4 through 15, inclusive. These two commands are typed at the `RESET` subcommand prompt.

```
DTC 3, 5, 9
```

```
DTC 4/15
```

**Description**

After entering the DTC subcommand, the following is printed on the terminal:

```
Warning: This will reset all users on that DTC. (TDSM 44)
```

```
Do you want to continue (yes/no)?
```

If you answer no to this question, you will be returned to the reset prompt. If you answer yes, the reset continues and the following messages are displayed:

```
The reset operation can take as long as 7 minutes.
```

The reset operation causes a DTC selftest to occur.

The DTC subcommand causes a complete DTC selftest to be run. This selftest includes the selftests for each of the interface cards within the DTC. All jobs or sessions that are running on devices connected to the DTC are aborted.

**NOTE**

The `RESET DTC` subcommand for a single DTC is functionally identical to the `SELFTEST DTC` subcommand of the `TermDSM DIAG` command. The inclusion of both commands is for your convenience.

If the selftest completes successfully, the results of each of the card selftests will be displayed. Refer to the `SIC` subcommand for the explanation of these results.

The DTC software is then downloaded to the DTC so that users may again use devices connected to the DTC. If you are running `TermDSM` at the system console, you will receive informational messages relating to this download.

You will then be returned to the reset prompt and may enter another `RESET` subcommand.

**R[ESET] L[DEV]**

Clears the software associated with a particular logical device number (and its associated port) so that the associated device may be used again.

Security level: 2.

**Syntax**

```
L[DEV] ldevnum
```

**Parameter**

*ldevnum*            The logical device number associated with the connection you want to reset.

**Description**

This subcommand also resets the port associated with this ldev number. Also, any session or job running on the device is aborted.

When it is complete, the reset prompt will be displayed and you can then enter another RESET subcommand.

**R[ESET] PO[RT]**

Clears the software associated with a particular port so that the associated device can be used again. Security level: 2.

**Syntax**

PO[RT] *dtcnum, cardnum, portnum*

**Parameters**

|                |  |
|----------------|--|
| <i>dtcnum</i>  | Number of the DTC to which the device is connected. This is the number TermDSM associates with this DTC.   |
| <i>cardnum</i> | Number of the interface card within the DTC to which the device is connected. The cards are numbered from zero beginning at the bottom of the DTC as you face the back of the DTC. |
| <i>portnum</i> | Number of the port on the interface card. The ports are numbered from zero beginning at the left of the board as you face the back of the DTC.                                     |

**Description**

This subcommand resets the ldev number that is currently associated with the port. It also aborts any session or job that is running on the port.

When it is complete, the reset prompt will be displayed and you can then enter another RESET subcommand.

**R[ESET] SI[C]**

Resets all ports of a specific Serial Interface Card in a specific DTC.

Security level: 2.

**Syntax**

SI[C] *dtcnum, cardnum*

**Parameters**

|                |  |
|----------------|--|
| <i>dtcnum</i>  | Number of the DTC to which the device is connected. This is the number TermDSM associates with this DTC.   |
| <i>cardnum</i> | Number of the interface card within the DTC to which the device is connected. The cards are numbered from zero beginning at the bottom of the DTC. |

### Description

When the subcommand is entered, all ports of the card are reset. When the reset completes, the status of each port of the card will be displayed.

The reset prompt will then be displayed and you can enter another `RESET` subcommand.

This subcommand should also be used when resets of a particular port on an SIC have been unsuccessful. If the reset of the card is also unsuccessful, consider using the `DTC` subcommand to reset the entire DTC.

### R[ESET] SN[P]

Resets the specific X.25 card in a specific DTC.

Security level: 2.

### Syntax

```
SN[P] dtcnum, cardnum
```

### Parameters

|                |  |
|----------------|--|
| <i>dtcnum</i>  | Number of the DTC that contains the X.25 (SNP) card. This is the number TermDSM associates with this DTC.  |
| <i>cardnum</i> | Number of the interface card within the DTC. The cards are numbered from zero beginning at the bottom of the DTC. (Note that SNP cards may not be mounted in slot 0 or 1 for DTC 16, and slot 0 for DTC 48.) |

### Description

When the subcommand is entered, the specified X.25 card is reset. All VCs on the X.25 card are reset (up to 256 VCs for DTC 48 and DTC 72MX, and up to 32 VCs for DTC 16).

After entering the `DTC` subcommand, the following is printed on the terminal:

```
Warning: This will abort all users on this SNP. As many
as 256 virtual circuit users could be affected. (TDSM 45)
Do you want to continue (yes/no)?
```

If you answer no to this question, you will be returned to the reset prompt. If you answer yes, the reset continues.

### R[ESET] V[C]

Resets the specific VC on an X.25 card in a specific DTC. (If the VC you are attempting to dump is a PAD VC, you must use the `Ldev` option instead.)

Security level: 2.

### Syntax

```
V[C] dtcnum, cardnum, vcnum
```

### Parameters

|               |   |
|---------------|---|
| <i>dtcnum</i> | Number of the DTC that contains the X.25 card (SNP). This is the number TermDSM associates with this DTC. |
|---------------|---|

|                |  |
|----------------|--|
| <i>cardnum</i> | Number of the X.25 card within the DTC. The cards are numbered from zero beginning at the bottom of the DTC. (Note that SNP cards may not be mounted in slot 0 or 1 for DTC 16, and slot 0 for DTC 48.)      |
| <i>vcnum</i>   | Number of the VC on the X.25 card within the DTC. On a DTC 48 or DTC 72MX, up to 256 VCs are supported. On a DTC 16, up to 32 VCs are supported. (PAD VCs must be reset using the <code>Ldev</code> option.) |

**Description**

When the subcommand is entered, the specified VC on an X.25 card is reset. Any job or session running on the VC will be aborted.

## **S[TATUS]**

Obtains information about DTC or port configuration and the state of the DTC or port.  
Security level: 2.

### **Syntax**

S[TATUS]

### **Description**

After the STATUS command is entered, the following prompt is printed on the terminal:

```
(status)

DTC #
Port #,#,#
SNP #,# ,#X.25 options - 1:Global, 2:level2,
3:level3, 4:PAD)
Vc #,#,#

(carriage return to exit) ? <F255P255>
```

These subcommands will display the status for the selected component or connection. The following pages describe these two options. The STATUS subcommands DO NOT affect the operation of the system, DTCs, or ports.

If you press **[Return]** instead of one of the subcommands, you will be returned to the major prompt and then may enter another TermDSM command.

## **S[TATUS] DT[C]**

Obtains configuration and status information about a particular DTC.  
Security level: 2.

### **Syntax**

DT[C] *dtcnum*

### **Parameter**

*dtcnum* This is the number TermDSM associates with a particular DTC. The DTC command lists each DTC with its assigned number. This is also printed when you make a mistake while typing in a DTC number.

### **Description**

When this subcommand is entered, a large amount of information related to the DTC is printed on the terminal.



The following is a brief explanation of key fields printed on the terminal:

- **Machine Type.** The HP product number of the DTC.
- **DTC Node Name.** The user-assigned node name of the DTC.
- **NOVRAM Value.** A code that indicates location of Nodal address and Boot Multicast address within DTC RAM.
- **Nodal address.** 802.3 station address of the DTC.
- **Boot Multicast address.** 802.3 multicast address which DTC uses when requesting its code file.
- **Host Node Address.** 802.3 address of MPE/iX system that downloaded the DTC.
- **DTC Lan Multicast Addresses.** These fields will be used by DTC diagnostics in future releases.
- **Selftest Status Readout.** Provides results of most recent DTC selftest. The first two columns list and identify SIC cards. The next two columns show status of the SICs. For details on the DTC selftest readout, refer to the description of the DIAG Selftest DTC subcommand.
- **Version Numbers.** The version numbers of hardware and software modules on the DTC.

The remaining fields provide a detailed record of DTC events. They tell what events are being logged (by MPE/iX) and list event frequencies. This information can be used by HP support representatives for detailed diagnosis of DTC problems. Further explanation of these fields is beyond the scope of this manual.

## S[TATUS] PO[RT]

Obtains status information about a particular port.

Security level: 2.

### Syntax

PO[RT] *dtcnum, cardnum, portnum*

### Parameters

|                |   |
|----------------|---|
| <i>dtcnum</i>  | The number TermDSM associates with a particular DTC. The DTC command lists each DTC with its assigned number. This list is also printed when you make a mistake while typing in a DTC number. |
| <i>cardnum</i> | Number of the interface card within the DTC to which the device is connected. The cards are numbered from zero beginning at the bottom of the DTC.  |
| <i>portnum</i> | Number of the port on the interface card. As you face the back of the DTC, the ports are numbered from zero beginning at the left of the board.   |

### Description

When this subcommand is entered, a large amount of information related to the port is printed on the terminal.

The following is a brief explanation of key fields displayed on the terminal:

- **Revision Number.** Provides version number of SIC hardware and software.
- **Current Host Name.** If a connection is active, and it was initiated by the terminal, then this is the name of the host to which the port is connected. Otherwise, this field is blank.
- **Port Type.** The type of DTC connector card attached to the port.
- **Connection State.** The status of the connection between the port and the MPE/iX system. Possible values are:
  - **Disconnected.** Port is not in use; no MPE/iX session is active on this port.
  - **Connect from AFCP Pending.** MPE/iX has requested and is awaiting a connection to this port.
  - **Connect from DIODAM Pending.** Device has requested and is awaiting a connection to the MPE/iX.
  - **Connected.** The port is connected to an MPE/iX system.
  - **Disconnect from AFCP Pending.** MPE/iX has requested and is awaiting disconnection from the port.
  - **Disconnect from DIODAM Pending.** Device has requested and is awaiting disconnection from MPE/iX.
  - **Bad.** The port has failed its selftest, or this is a non-existent port on the SIC.

The remaining fields contain detailed diagnostics information for use by HP support representatives. Further explanation of these fields is beyond the scope of this manual.

## S[TATUS] SN[P]

Obtains status information about a particular X.25 card.

Security level: 2.

### Syntax

SN[P] *dtnum, cardnum, optionnum*

### Parameters

|                  |   |
|------------------|---|
| <i>dtnum</i>     | Number of the DTC that contains the X.25 (SNP) card. This is the number TermDSM associates with this DTC.   |
| <i>cardnum</i>   | Number of the X.25 card within the DTC. The cards are numbered from zero beginning at the bottom of the DTC. (Note that SNP cards may not be mounted in slot 0 or 1 for DTC 16, and slot 0 for DTC 48.)       |
| <i>optionnum</i> | Number of the option. One of the following four options must be specified: <ul style="list-style-type: none"><li>1 for global</li><li>2 for level 2</li><li>3 for level 3</li><li>4 for PAD status.</li></ul> |

**Description**

When this subcommand is entered, a large amount of information related to the X.25 card is printed on the terminal.

---

## VC

Obtains status information about a particular VC on an X.25 card.

Security level: 2.

### Syntax

```
V[C] dtnum, cardnum, vnum
```

### Parameters

|                |   |
|----------------|---|
| <i>dtnum</i>   | Number of the DTC that contains the X.25 (SNP) card. This is the number TermDSM associates with this DTC.   |
| <i>cardnum</i> | Number of the X.25 card within the DTC. The cards are numbered from zero beginning at the bottom of the DTC. (Note that SNP cards may not be mounted in slot 0 or 1 for DTC 16, and slot 0 for DTC 48.) |
| <i>vnum</i>    | Number of the VC. There can be up to 256 VCs on a DTC48 or DTC 72MX and up to 32 VCs on a DTC16.  |

### Description

When this subcommand is entered, detailed information about the selected Virtual Connection for a PAD or X.25 system connection is printed on the terminal. The VC number can be determined by examining the output from the CONNECT command and SHOW subcommand for PAD devices and the MULTI command and LIST subcommand for the X.25 system to system connections. The connection is listed as the LCI (Logical Connection Id) number in those displays.

---

## T[RACE]

Turns on a trace for a specific port on an asynchronous processor board of a DTC 72MX or a specific VC, level 2, or level 3 on an X.25 card (for a DTC 16, DTC 48, or DTC 72MX).

Security level: 2.

### Syntax

T[RACE]

### Description

After the command is entered, the following prompt is printed on the terminal:

```
(TIO or X25)
```

```
TIO
```

```
X25
```

```
(carriage return to exit) ?
```

TIO specifies tracing on a selected port of an asynchronous processor board (mux card) of a DTC 72MX.

X25 specifies tracing on an X.25 card on a DTC 16, DTC 48, or DTC 72MX.

## T[RACE] TI[O]

Specifies tracing on a selected asynchronous port of a DTC 72MX. TRACE TIO is not supported for ports on DTC 16s or DTC 48s.

Security level: 2

### Syntax

T[RACE] TI[O]

### Description

After the command is entered, the following prompt is printed on the terminal:

```
(tio trace)
```

```
TRACEON #, #, #
```

```
TRACEOff #, #
```

```
TRACEShow #
```

```
(carriage return to exit) ?
```

These are the subcommands that can then be entered. The following pages describes these options.

If you press **[Return]** instead of one of these subcommands, you will be returned to the TRACE main prompt and then may specify TRACE TIO or TRACE X25.

## T[RACE] TI[O] TRACEON

Starts extended tracing on a selected port of an asynchronous processor board in a DTC 72MX.

Security level: 2

### Syntax

```
TRACEON dtnum, boardnum, portnum
```

### Parameters

|                 |   |
|-----------------|---|
| <i>dtnum</i>    | The number TermDSM associates with a particular DTC. The DTC command lists each DTC with its assigned number. This list is also printed when you make a mistake while typing in a DTC number. |
| <i>boardnum</i> | Number of the asynchronous processor board within a DTC 72MX which contains the port to be traced.  |
| <i>portnum</i>  | Number of the port on which tracing is to be done. As you face the back of the DTC, the ports are numbered from zero beginning at the left of the board.                                      |

### Description

TRACE TIO is used to specify extended tracing on a selected port of an asynchronous processor board (mux card) on a DTC 72MX.

Normally traced data is kept in a circular buffer for each port. When extended tracing on a selected port is specified, the size of the buffer for the port is extended, while the size of the trace area for the other ports on the same board is reduced.

Only one port per board may have extended tracing active at one time. TRACEON starts extended tracing. No trace file is created with the trace. You need to perform a DUMP PORT to store the trace data into a disk file.

Use TRACEOFF to stop tracing.

---

### NOTE

---

Tracing a port and dumping information pertaining to a port does not reset (or otherwise affect) the associated device. If you need to reset the device, use the RESET command.

## T[RACE] TI[O] TRACEOF[F]

Turns off extended tracing of an asynchronous port on a DTC 72MX. Security level : 2.

### Syntax

```
TRACEOF[F] dtnum, boardnum
```

**Parameters**

|                 |   |
|-----------------|---|
| <i>dtcnum</i>   | Number of the DTC that contains the asynchronous board with a port that is being traced. This is the number TermDSM associates with this DTC. |
| <i>boardnum</i> | Number of the asynchronous board that contains the port being traced.   |

**Description**

TRACEOFF turns off extended trace on a port. You must turn off tracing on a port before starting extended tracing on another port on the same board.

After TRACEOFF is issued, the trace information will be overwritten. In order to keep the trace information, do a DUMP PORT before the TRACEOFF subcommand.

**T[RACE] TI[O] TRACES[HOW]**

Lists all the ports on the specified DTC 72MX that currently have extended tracing on.

Security level: 2.

**Syntax**

```
TRACES[HOW] dtcnum
```

**Parameter**

|               |  |
|---------------|--|
| <i>dtcnum</i> | Number of the DTC 72MX that has extended tracing on for one or more of its asynchronous processor boards. This is the number TermDSM associates with this DTC. |
|---------------|--|

**T[RACE] X2[5]**

Specifies tracing for a particular VC on an X.25 card on a DTC 16, DTC 48, or DTC 72MX.

Security level: 2.

**Syntax**

```
T[RACE] X2[5]
```

**Description**

After the command is entered, the following prompt is printed on the terminal:

```
(X25 trace)
```

```
TRACEON #, #, #
```

```
TRACEOFF
```

```
(carriage return to exit) ?
```

TRACEON and TRACEOFF are subcommands that can be entered with the TRACE X25 command. The following pages describes these options.

When you specify tracing on an X.25 card, you will also be prompted to enter a file name for the trace file. You can specify the name of the file that will contain the trace information by entering a valid MPE file name. If you want to use the default trace file (X25TRACE.PUB.SYS), press return without specifying a file name.

## T[RACE] X2[5] TRACEON

Turns on a trace for a particular VC on an X.25 card.

Security level: 2.

### Syntax

TRACEON *dtnum, cardnum, traceoption*

### Parameters

|                    |   |
|--------------------|---|
| <i>dtnum</i>       | Number of the DTC that contains the DTC/X.25 Network Access card (SNP). This is the number TermDSM associates with this DTC.  |
| <i>cardnum</i>     | Number of the SNP card within the DTC. The cards are numbered from zero beginning at the bottom of the DTC. (Note that SNP cards may not be mounted in slot 0 or 1 for DTC 16, and slot 0 for DTC 48.)  |
| <i>traceoption</i> | The trace option allows you to specify the type of information that you want included in the trace. The options are 1, to trace VC information; 2, to trace level 2 information; or 3, to trace level 3 information. The trace options are described separately on the following pages. Only one trace can be active at a time. |

**Trace Option 1** Use trace option 1 to trace information about a specific VC. When this trace option is entered, the following prompt is printed on the terminal:

```
(VC number)
vc #
(carriage return to exit) ?
```

Enter the number of the virtual circuit for which you want the trace recorded. There can be up to 256 VCs on a DTC48 or DTC 72MX and up to 32 VCs on a DTC16.

You will then see the following prompt at the terminal:

```
(filter)

HDr          Header only)
FUll         (Full Packet)

(carriage return to exit) ?
```

Enter HDr if you want only header information (including TCP/IP headers) included in the trace.

Enter FUll if you want full packet information included in the trace.

You will then be prompted to enter a trace file name, as follows:

```
(Filename)
```



Please enter a filename for the X.25 trace or press carriage return to use the default (TRACE.PUB.SYS). Trace file will be kept in PUB.SYS.

(carriage return to accept default) ?

**Trace Option 2** Use trace option 2 to trace level 2 information for the specified SNP card. When this trace option is entered, the following prompt is printed on the terminal:

(filter)

HDr           (Header only)

FUll          (Full Packet)

(carriage return to exit) ?

Enter HDr if you want only header information (including TCP/IP headers) included in the trace.

Enter FUll if you want full packet information included in the trace.

You will then be prompted to enter a trace file name, as follows:

(Filename)

Please enter a filename for the X.25 trace or press carriage return to use the default (TRACE.PUB.SYS). Trace file will be kept in PUB.SYS.

(carriage return to accept default) ?

**Trace Option 3** Use trace option 3 to trace level 3 information for the specified SNP card. When this trace option is entered, the following prompt is printed on the terminal:

(VC type for level 3)

PAd           PAD VCs)

SYS          (System-to-System VCs)

All          (PAD and System-to-System VCs)

(carriage return to exit) ?

Enter PAd to trace PAD VCs only, enter SYS to trace system-to-system VCs only, enter All to trace both PAD and system-to-system VCs.

You will then be asked to enter the link name, as follows:

(linkname)

Please enter the linkname for level 3 trace

**T[RACE]**

(carriage return to exit) ?

Enter the link name of the X.25 link as configured in NMMGR. The link name may be up to eight (8) ASCII characters.

You will then see the following prompt at the terminal:

(filter)

HDr            (Header only)

FUll           (Full Packet)

(carriage return to exit) ?

Enter HDr if you want only header information (including TCP/IP headers) included in the trace.

Enter FUll if you want full packet information included in the trace.

You will then be prompted to enter a trace file name, as follows:

(Filename)

Please enter a filename for the X.25 trace or press carriage return to use the default (TRACE.PUB.SYS). Trace file will be kept in PUB.SYS.

(carriage return to accept default) ?

**T[RACE] X2[5] TRACEOF[F]**

Turns off a trace for a VC, level 2, or level 3 on an X.25 card.

Security level: 2.

**Syntax**

TRACEOF [F]

**Description**

Turns off the trace activated through a previous TRACEON command. Since only one trace can be active at a time, this command does not require any parameters.

---

## X25SITE

The X.25 Site Management function displays information on X.25 system-to-system connections between MPE/iX systems..

Security level: 2.

### Syntax

```
X[25site]
```

### Description

The connection information that can be displayed covers three areas.

- Information on the DTCs managed by the MPE/iX system where TermDSM is running
- Information on the an X.25 link between the DTC and the PSN
- Information about the second system. This system is called the remote system in the displayed information

The information is displayed in three tables.

- The first table lists all the system-to-system links that are active on all the DTC that the system is managing.
- The second table lists all the connections that are established through one of the selected links.
- The third display presents detailed information on one connection selected from the list of connections.

The X.25 Site Management subsection has the following subcommands:

```
(X.25 Site Management)
```

```
Map      - Display the X.25 Active Site Network
List #   - Display the Connectivity list for selected Network
Status # - Display the VC status for selected connection.
```

```
(carriage return to exit) ?
```

When the X25SITE command is first entered, only the MAP subcommand is available. When the X.25 Active Site Network table is completed, then you can enter the MAP command to redisplay the Active Network map or the LIST command to select one of the links and display the Connectivity List. Once the LIST command is entered, then you can enter the STATUS command to display information about a selected Virtual Connection (or LCI number).

[CTRL]-Y can be used during execution of any of the above subcommands to stop the output.

The following sections describe the subcommands.

## MAP

The MAP command displays the X.25 Active Site Network table. This table lists all the NS links that are configured through all the DTCs that the system is managing.

Security level: 2.

### Syntax

M[ap]

### Description

When this command is executed, TermDSM will query all the X.25 cards in all DTC that are being managed by the system and generate a table that lists the following information:

- The node name of the MPE/iX system that is managing this link (the name may be truncated)
- The node name of the MPE/iX system that is managing this link (the name may be truncated)
- The DTC node name and the board that is configured for the link (the name may be truncated)

The **MAP** command displays the output as follows:

```
      X.25 Active Site Network
Netwk# System Node Name           Link Name  DTC Node Name           Board#
=====
001  SYSTEMA.DOMAIN.ORG           X25LINK1  DTSBTC01.DOMAIN.ORG     0001
002  SYSTEMB.DOMAIN.ORG           X25LINK2  DTSBTC02.DOMAIN.ORG     0001
```

Each entry is identified by a Network number. This network number is used in the LIST subcommand to specify which network connectivity list to be displayed.

## LIST

The LIST subcommand displays the Connectivity List table for the selected network which contains information on all the connections that are currently established through the Network Link.

Security level: 2.

### Syntax

LI[st] netwk

Parameter

### Parameter

*netwk* This is the number that is displayed for each link in the Active Site Network table by the MAP subcommand.

**Description**

When this command is executed, TermDSM will gather information about all the connections that are established through the selected link. This information is displayed in the Connectivity List. The connectivity list consists of the header that contains detailed information about the Link, and a table that lists information about each connection. The header contains the following information:

- The full system NS node name
- The NS link name
- The full DTC NS node name
- The DTC's IP address
- The Board number in the DTC

The Connectivity table contains the following information about each connection:

- The Virtual Circuit number
- The NS Node name of the remote system (the name may be truncated)
- The X.25 address of the connection, or the string 'PVC' if this is a Private Virtual Connection
- The type of connection established

Each connection is identified by a Virtual Circuit number. This VC number is used in the **STATUS** subcommand to specify on which connection the detailed information is to be displayed.

The following is an example of the data displayed in the X.25 Connectivity List:

```

X.25 Connectivity List

System Node Name: SYSTEMA.DOMAIN.ORG
Link Name:       X25LINK1
Local IP Address: C 192.10.11.12
DTC Node Name:   DTSBTC01.DOMAIN.ORG
Board Number:    2

=====
Virtual
Port# Remote Node Name X.25 Address/PVC Conn Type
=====
0001  SYSTEMZ.DOMAIN.O  123456789012345  Level 3.
0002  <POOL>             123456789012346  TCP/IP..
0256  SYSTEMB.DOMAIN.O  PVC              Level 3.

```

**STATUS**

The STATUS subcommand displays detailed information about a selected Virtual Circuit established through an X.25 card..

Security level: 2.

**Syntax**

```
STAT[us] vcnbr
```

**Parameter**

*vcnbr* This is the Virtual Circuit number that is displayed for each connection in the Connectivity table by the LIST subcommand. There can be up to 256 VCs on a DTC 72MX or DTC48 and up to 32 VCs on a DTC16.

**Description**

When this subcommand is entered, detailed information on many parameters and counters for a selected Virtual Circuit is displayed on the terminal.

---

# A TermDSM Messages

- (TDSM 15) **MESSAGE: You have entered an unknown or incorrect command. Please try again. (TDSM 15)**
- CAUSE: You have entered something that is not a TermDSM command or a command that is not valid in this context.
- ACTION: Commands that are valid at this time are listed in the prompt. Please try again. Type `HELP` or refer to Chapter 4, “TermDSM Commands,” for more information.
- (TDSM 16) **MESSAGE: TermDSM has compiled without \$partial eval\$ in effect. It cannot continue. This problem must be fixed at the factory. (TDSM 16)**
- CAUSE: Internal error.
- ACTION: Contact your Hewlett-Packard support representative.
- (TDSM 17) **MESSAGE: Your security level (3) is too low to use TermDSM. Please log on with level 0, 1, or 2 security. (TDSM 17)**
- For level 0, you need SM capability.**
- For level 1, you need SM or DI capability.**
- For level 2, you need SM or DI or OP capability.**
- CAUSE: You do not have the correct user capabilities to use TermDSM.
- ACTION: Logon as a user with the correct capabilities for the TermDSM functions you wish to use. Refer to Chapter 4, “TermDSM Commands,” for the security levels of each command and subcommand.
- (TDSM 18) **MESSAGE: You have entered a bad port number. Port numbers range from 0 to 23. (TDSM 18)**
- CAUSE: You have entered an invalid port number. Port numbers range from 0 to 7 for DTC 16 and DTC 48, from 0 to 15 for DTC 16iX/16MX, and from 0 to 23 for DTC 72MX.
- ACTION: The port number was not entered or is unrecognizable.
- (TDSM 19) **MESSAGE: The port number is missing or invalid. Port numbers range from 0 to 23. (TDSM 19)**
- CAUSE: Internal error.
- ACTION: Enter a valid port number. Refer to the prompt or Chapter 4, “TermDSM Commands,” for syntax.
- (TDSM 20) **MESSAGE: You have entered a bad ldev number. Ldev numbers are positive integers. (TDSM 20)**
- CAUSE: The value that you entered as a logical device number is not a number greater than zero.
- ACTION: Enter a valid ldev number. Note that you can also use the `PORT` subcommand.
- (TDSM 21) **MESSAGE: The ldev number is missing or invalid. Ldev numbers are positive integers. (TDSM 21)**
- CAUSE: The logical device number was not entered or is unrecognizable.
- ACTION: Enter a valid ldev number. Note that you can also use the `PORT` subcommand.

- (TDSM 22) MESSAGE: You have entered an invalid SIC card number. SIC card numbers range from 0 to 5. (TDSM 22)**
- CAUSE: The card number that you entered is not in the range from zero to five. Card number range from 0 to 1 for DTC 16, 1 for DTC 16iX/16MX, from 0 to 5 for DTC 48, and from 0 to 3 for DTC 72MX.
- ACTION: Double check the card numbers by looking at the back of the DTC. Enter the card number again.
- (TDSM 23) MESSAGE: The SIC card number is missing or invalid. SIC card numbers range from 0 to 5. (TDSM 23)**
- CAUSE: The card number was not entered or is unrecognizable.
- ACTION: Enter the card number again. Refer to the prompt or Chapter 4, "TermDSM Commands," for syntax.
- (TDSM 24) MESSAGE: You have entered an incorrect DTC number. Please choose a "DTC number" from this list. (TDSM 24)**
- CAUSE: The value entered does not correspond with any DTC on the system.
- ACTION: The DTCs on the system are listed with their numbers. Enter one of the numbers displayed.
- (TDSM 25) MESSAGE: The DTC number is missing or invalid. Please choose a DTC number from this list. (TDSM 25)**
- CAUSE: The DTC number was not entered or is unrecognizable.
- ACTION: The DTCs on the system are listed with their numbers. Enter one of the numbers displayed.
- (TDSM 27) MESSAGE: TermDSM cannot do the dump because there are already too many dump files. Please purge some. Dump files are of the form TRMnnnaa.PUB.SYS. where nnn is a 3 digit number and aa is 2 alphabetic characters. (TDSM 27)**
- CAUSE: The dump files TRMdddAA through TRMdddZZ already exist. (The sequence ddd is the current Julian date.)
- ACTION: Delete some files beginning with the file called TRMdddAA since this is the oldest file. Note that if all files for this Julian date already exist, there are over 600 dump files for today. You can delete most of these files.
- (TDSM 28) MESSAGE: You need to issue a "Map" command first. (TSDM 28)**
- CAUSE: The **MAP** command has not yet been entered to generate the X.25 Active Site Network table after the X25SITE subfunction was entered. The **MAP** command must be executed before the "**List**" or "**Status**" commands can be issued.
- ACTION: Enter the **MAP** command to generate the X.25 Active Site Network table.
- (TDSM 30) MESSAGE: You need to issue a "List" command first. (TSDM 30)**
- CAUSE: The **LIST** command has not yet been entered to generate the X.25 Connectivity List table after the X25SITE subfunction was entered. The **LIST** command must be executed before the "**Status**" command can be issued.



**ACTION:** Enter the **LIST** command to generate the X.25 Connectivity List for a selected link.

**(TDSM 32) MESSAGE: Your security level (3) is too low to take dumps. Please log on with level 2 security to dump ports, or level 1 security to dump ports and DTCs. (TDSM 32)**

**For level 1, you need SM or DI capability.**

**For level 2, you need SM or DI or OP capability.**

**CAUSE:** You do not have the correct user capabilities to use this function.

**ACTION:** Log on with level 0, 1, or 2 security. Refer to Chapter 4, “TermDSM Commands,” for the security levels of each command and subcommand.

**(TDSM 33) MESSAGE: Your security level is too low to reprogram EEPROM. Please log on with level 1 security to reprogram EEPROM. (TDSM 33)**

**For level 1, you need SM or DI capability.**

**CAUSE:** You do not have the correct user capabilities to use this function.

**ACTION:** Log on with level 1 security. Refer to Chapter 4, “TermDSM Commands,” for the security levels of each command and subcommand.

**(TDSM 34) MESSAGE: That ldev does not exist. Please check the ldev number, or dump the associated port instead. (TDSM 34)**

**CAUSE:** Although you entered a number in a range that could be an ldev number, that ldev number is not configured on the system.

**ACTION:** Verify the ldev number by entering the **SHOWJOB** command. You can also dump information associated with the device by using the **PORT** subcommand (which uses the physical address instead of the ldev number).

**(TDSM 35) MESSAGE: Someone else is using TermDSM to troubleshoot that DTC. Find that person and have them exit TermDSM. If you cannot locate that user, you may override them. (TDSM 35)**

**CAUSE:** More than one person is using TermDSM and directing operations to the same DTC at the same time.

**ACTION:** It is permissible for two or more users to run TermDSM simultaneously as long as the users do not reference the same DTC. In this case, message 35 will not appear.

If one TermDSM user chooses to override another by continuing, it is likely that the overridden TermDSM will produce error messages.

The override facility is provided for the case where a terminal running TermDSM is hung and therefore cannot exit the program. Note that if one TermDSM user resets the port of another TermDSM user, this can cause the system to go down.

**(TDSM 36) MESSAGE: No ldevs seem to be configured on your system. ( TDSM36)**

**CAUSE:** Necessary configuration information does not exist on the system.

**ACTION:** Make sure the file **NMCONFIG.PUB.SYS** exists. Bring the system down and back up again, making sure that the proper **SYSGEN** files are used. (The **SYSGEN** files used are determined by the boot path. The file **NMCONFIG.PUB.SYS** is used automatically.) If the problem persists, contact your HP support representative.

**(TDSM 37) MESSAGE: The dump process can't find out the length of the data area. (TDSM 37)**

**CAUSE:** Internal error.

ACTION: Contact your HP support representative.

**(TDSM 38) MESSAGE: The data area is longer than TermDSM's dump buffer. (TDSM 38)**

CAUSE: Internal error.

ACTION: Contact your HP support representative.

**(TDSM 39) MESSAGE: TermDSM never received a reply to its dump data area request. (TDSM 39)**

CAUSE: Internal error.

ACTION: Contact your HP support representative.

**(TDSM 42) MESSAGE: You must have high (1) security to perform this function. (TDSM 42)**

**For level 1, you need SM or DI capability.**

CAUSE: You do not have the correct user capabilities to use this function.

ACTION: Logon as a user with the correct capabilities for the TermDSM functions you wish to use. Refer to Chapter 4, "TermDSM Commands," for the security levels of each command and subcommand.

**(TDSM 43) MESSAGE: You can't do this from your own DTC. Please run TermDSM from another DTC or from the console. (TDSM 43)**

CAUSE: If you were permitted to selftest, dump, or reset the DTC to which you are logged on, your session would be aborted and you would be unable to get the test results.

ACTION: Move to a terminal on another DTC or the system console to run TermDSM.

**(TDSM 44) MESSAGE: Warning: This will reset all users on that DTC. (TDSM 44)**

CAUSE: If you continue, all user sessions on this DTC will be aborted.

ACTION: If you want to continue, you should alert all the users that their sessions will be aborted.

**(TDSM 45) MESSAGE: Warning: This will reset all users on that SNP. As many as 256 virtual circuits could be affected. (TDSM 45)**

CAUSE: If you continue, all user sessions on this SNP will be aborted.

ACTION: If you want to continue, you should alert all the users that their sessions will be aborted.

**(TDSM 46) MESSAGE: That virtual port number was not found. Please choose a port number from this list: (TDSM 46))**

CAUSE: The virtual port number entered in the STATUS command was not valid. Either the incorrect number was entered or the connection is no longer established.

ACTION: Termdsm will redisplay the connectivity list. Check the virtual port number and reenter the STATUS command with the correct number.

**(TDSM 49) MESSAGE: Warning: This will abort all users on that MUX. As many as 24 users could be affected. (TDSM 49)**

CAUSE: If you continue, all user sessions on this asynchronous processor board (mux card) on the DTC 72MX will be aborted.

ACTION: If you want to continue, you should alert all the users that their sessions will be aborted.

- (TDSM 50) **MESSAGE: Warning: There will be no file created to keep the trace data. To get the trace data, please perform a port dump BEFORE stopping the trace. (TDSM 50)**
- CAUSE: Extended tracing on a port on an asynchronous processor board will not be stored into a disk file.
- ACTION: Before terminating an extended tracing on a port with TRACEOFF, do a port dump to keep the trace data into a disk file.
- (TDSM 51) **MESSAGE: Warning: The trace data will be overwritten by this command. To get the trace data, please perform a port dump first. (TDSM 51)**
- CAUSE: This warning is issued when you enter the TRACEOFF subcommand.
- ACTION: To save the trace data on an asynchronous port, do a port dump before issuing the TRACEOFF subcommand to terminate extended tracing.
- (TDSM 53) **MESSAGE: Each DTC selftest can take as long as 7 minutes. Enter a Control-Y to stop the selftest loop (the Control-Y will take effect when the current selftest finishes). (TDSM 53)**
- CAUSE: This warning is issued when you issue a SELFTEST subcommand to initiate DTC selftest.
- ACTION: Continue with the DTC selftest if you want. You can terminate selftest anytime by pressing [CTRL]-Y.
- (TDSM 56) **MESSAGE: Your answer must be at least 1 and no more than 65535. (TDSM 56)**
- CAUSE: The value entered is not in the range 1 to 65535.
- ACTION: Enter a value in the range. Diagnostic loop counts are limited to this range.
- (TDSM 63) **MESSAGE: Please deliver the following SNP dump to your HP representative. (TDSM 63)**
- CAUSE: Informational message.
- ACTION: Document the problem (the reason you took the dump), and deliver it to your HP support representative along with the dump file, preferably on magnetic tape.
- (TDSM 64) **MESSAGE: The following two files make up the DTC dump. Please deliver both to your HP representative. (TDSM 64)**
- CAUSE: Document the problem (the reason you took a dump), and deliver it to your HP support representative along with the dump files, preferably on magnetic tape.
- ACTION: Please deliver the following VC dump to your HP representative. (TDSM 65)
- (TDSM 65) **MESSAGE: Please deliver the following VC dump to your HP representative. (TDSM 65)**
- CAUSE: Informational message.
- ACTION: Document the problem (the reason you took a dump), and deliver it to your HP support representative along with the dump files, preferably on magnetic tape.
- (TDSM 70) **MESSAGE: There are no DTCs configured on your system. (TDSM 70)**
- CAUSE: Necessary configuration information does not exist on the system.
- ACTION: Check the NMCONFIG.PUB.SYS file for proper DTC configuration (using :NMMGR). Bring the system down and back up again. If the problem persists, contact your HP support representative.

- (TDSM 71) MESSAGE: There are more DTCs on your system than TermDSM can reference. Here are the ones TermDSM can reference. (TDSM 71)**
- CAUSE: You are using more than 120 DTCs on the system. You will not be able to perform any TermDSM functions on any DTCs that are not listed in this message.
- ACTION: Contact your HP support representative.
- (TDSM 80) MESSAGE: You can't reset your own port or ldev. Please run TermDSM from a different port or ldev to do this. (TDSM 80)**
- CAUSE: Verify the ldev numbers entered. If you want to reset a port, you cannot be logged on to that port; the operation will abort your session.
- ACTION: If you want to reset the port you are using, move to another port or the system console to run TermDSM.
- (TDSM 81) MESSAGE: That ldev is unknown (not configured). Please check the ldev number, or use reset port. (TDSM 81)**
- CAUSE: Although a number was entered in a range that could be an ldev number, that number is not configured on the system.
- ACTION: Verify the ldev number by entering the `SHOWJOB` command. You can also reset ports by using the `PORT` subcommand (which uses the physical address instead of the ldev number).
- (TDSM 82) MESSAGE: You must have high (1) or medium (2) security to do resets, and high (1) security to reset DTCs. (TDSM 82)**
- For level 1, you need SM or DI capability.**
- For level 2, you need SM or DI or OP capability.**
- CAUSE: You do not have the correct user capabilities to do this function.
- ACTION: Logon as a user with the correct capabilities for the functions you wish to use. Refer to Chapter 4, "TermDSM Commands," for the security level of each command and subcommand.
- (TDSM 83) MESSAGE: The specified local X.25 link appears to have just shut down. Please try again or do a new "Map" command. (TDSM 83)**
- CAUSE: The link requested is configured on the local system and TermDSM attempted to get the Connection list from the local system for the selected link but The link is no longer up.
- ACTION: Reenter the `MAP` command and verify if the selected link is displayed in the map table. Check that the correct entry number was entered.
- (TDSM 84) MESSAGE: The specified remote X.25 link was not accessible. (TDSM 84)**
- CAUSE: TermDSM attempted to get the Connection list from the remote system for the selected link but the remote system did not return any data to the local system.
- ACTION: Verify that the X.25 link on the remote system is started and retry the `MAP` and then the `LIST` command.
- (TDSM 86) MESSAGE: You must have high (1) or medium (2) security to test ports, and high (1) security to selftest DTCs. (TDSM 82)**
- For level 1, you need SM or DI capability.**

**For level 2, you need SM or DI or OP capability.**

CAUSE: You do not have the correct user capabilities to do this function.

ACTION: Logon as a user with the correct capabilities for the functions you wish to use. Refer to Chapter 4, “TermDSM Commands,” for the security level of each command and subcommand.

**(TDSM 93) MESSAGE: TermDSM could not open the DTC manager, so the DTC dump could not be obtained. (TDSM 93)**

CAUSE: Internal error, unless another TermDSM was being run against that same DTC and you chose not to override the other user. There is no error in this case.

ACTION: Contact your HP support representative (if it is an internal error).

**(TDSM 110) MESSAGE: You can't test your own port. Please run TermDSM from another port. (TDSM 110)**

CAUSE: Double check the numbers entered. If you wish to test a port, you cannot be logged on to that port; the operation will abort your session and you will be unable to obtain the results of the test.

ACTION: If you want to test the port to which you are logged on, move to another port or the system console to run TermDSM.

**(TDSM 113) MESSAGE: Please put a loopback hood on the port, before answering the “How many times?” question. (TDSM 113)**

CAUSE: A loopback hood must be in place before the diagnostic is run.

ACTION: Place loopback hood on the port and continue.

**(TDSM 114) MESSAGE: Please connect and make ready (power on, remote mode, etc.) a supported terminal, before answering the 'How many times?' question. (TDSM 114)**

CAUSE: The hardware must be present before the diagnostic is run.

ACTION: Make a supported terminal ready and continue.

**(TDSM 115) MESSAGE: Please connect and make ready (power on, remote mode, etc.) a supported printer (or terminal), before answering the “How many times?” message. (TDSM 115)**

CAUSE: The hardware must be present before the diagnostic is run.

ACTION: Make a supported printer (or terminal) ready and continue.

**(TDSM 118) MESSAGE: You can't reprogram EEPROM on your own DTC. Please run TermDSM from another DTC or from the console. (TDSM 118)**

CAUSE: Your own session is on this DTC. If you wish to reprogram EEPROM, you can't be logged onto that DTC; the operation will abort your session and you will be unable to obtain the results.

ACTION: Move to a port on a different DTC or to the system console to run TermDSM.

**(TDSM 121) MESSAGE: Warning: The LDM dump is suspect. Consecutive dumps did not match. (TDSM 121)**

CAUSE: This message is written to dump files and never appears as an error message to a user. There was activity during the dump process, so part of the dump relating to the Logical Device Manager might be inconsistent with the rest of the dump.

ACTION: Submit the dump to your HP support representative.

- (TDSM 122) **MESSAGE: You can't reset your own SIC. Please run TermDSM from another SIC or DTC, or from the console. (TDSM 122)**
- CAUSE: Your own session is on this SIC (serial interface card). If you wish to reset a SIC, you cannot be logged onto that card; the operation will abort your session and you will be unable to obtain the results.
- ACTION: Move to a port on a different DTC or SIC, or to the system console, to run TermDSM.
- (TDSM 123) **MESSAGE: You can't reset your own SNP. Please run TermDSM from another PAD or SIC or DTC, or from the console.**
- CAUSE: Your own session is on this SNP (DTC/X.25 XL Network Access card). If you wish to reset an SNP you cannot be logged onto that card.
- ACTION: Move to a port on a different PAD, DTC, or SNP, or to the system console, to run TermDSM.
- (TDSM 124) **MESSAGE: You can't dump your own SNP. Please run TermDSM from another PAD or SIC or DTC, or from the console.**
- CAUSE: Your own session is on this SNP (DTC/X.25 XL Network Access card). If you wish to dump an SNP you cannot be logged onto that card.
- ACTION: Move to a port on a different PAD, DTC, or SNP, or to the system console, to run TermDSM.
- (TDSM 180) **MESSAGE: The Distributed Terminal Subsystem software does not exist. Please verify that the NMCONFIG.PUB.SYS file is correct and validated, and the system has booted up without errors. This situation prevents TermDSM from continuing. (TDSM 180)**
- CAUSE: The NMCONFIG.PUB.SYS file does not exist, or has no DTCs configured.
- ACTION: Check the NMCONFIG.PUB.SYS file for proper DTC/terminal configurations and validate (using NMMGR), then shutdown and restart the system.
- (TDSM 218) **MESSAGE: End of Record received. Time = xx msec. (TDSM 218)**
- CAUSE: Probable hardware failure.
- ACTION: Contact you HP support representative. You can obtain additional information by running the card selftest (through the SIC subcommand of the TermDSM RESET command), the DTC selftest, and the DTC offline diagnostics.
- (TDSM 219) **MESSAGE: Too many characters came back. Time = xx msec. (TDS M219)**
- CAUSE: More characters were returned than were sent. Someone might have pressed a key on the terminal under test, if this was a terminal loopback. Probable hardware failure.
- ACTION: Contact you HP support representative. You can obtain additional information by running the card selftest (through the SIC subcommand of the TermDSM RESET command), the DTC selftest, and the DTC offline diagnostics.
- (TDSM 219) **MESSAGE: Too many characters came back. Time = xx msec. (TDS M219)**
- CAUSE: More characters were returned than were sent. Someone might have pressed a key on the terminal under test, if this was a terminal loopback. Probable hardware failure.

**ACTION:** Contact you HP support representative. You can obtain additional information by running the card selftest (through the SIC subcommand of the TermDSM RESET command), the DTC selftest, and the DTC offline diagnostics.

**(TDSM 220) MESSAGE: Parity error. Time = xx msec. (TDSM 220)**

**CAUSE:** Probable hardware failure.

**ACTION:** Contact you HP support representative. You can obtain additional information by running the card selftest (through the SIC subcommand of the TermDSM RESET command), the DTC selftest, and the DTC offline diagnostics.

**(TDSM 220) MESSAGE: Parity error. Time = xx msec. (TDSM 220)**

**CAUSE:** Probable hardware failure.

**ACTION:** Contact you HP support representative. You can obtain additional information by running the card selftest (through the SIC subcommand of the TermDSM RESET command), the DTC selftest, and the DTC offline diagnostics.

**(TDSM 221) MESSAGE: Hardware receive overrun. Time = xx msec. (TDSM 221)**

**CAUSE:** Probable hardware failure.

**ACTION:** Contact you HP support representative. You can obtain additional information by running the card selftest (through the SIC subcommand of the TermDSM RESET command), the DTC selftest, and the DTC offline diagnostics.

**(TDSM 222) MESSAGE: Framing error. Time = xx msec. (TDSM 222)**

**CAUSE:** Probable hardware failure.

**ACTION:** Contact you HP support representative. You can obtain additional information by running the card selftest (through the SIC subcommand of the TermDSM RESET command), the DTC selftest, and the DTC offline diagnostics.

**(TDSM 223) MESSAGE: SIC Buffer overflow. Time = xx msec. (TDSM 223)**

**CAUSE:** Internal error.

**ACTION:** Contact you HP support representative.

**(TDSM 226) MESSAGE: No record separator in Vplus. Time = xx msec. (TDSM 226)**

**CAUSE:** Probable hardware failure.

**ACTION:** Contact you HP support representative. You can obtain additional information by running the card selftest (through the SIC subcommand of the TermDSM RESET command), the DTC selftest, and the DTC offline diagnostics.

**(TDSM 229) MESSAGE: Read timeout (no data came back). Time = xx msec. If external loopback, check loopback hood. If terminal loopback, check connections, terminal configuration, etc. (TDSM 229)**

**CAUSE:** No or too few characters came back from the loopback.

**ACTION:** If this is an internal loopback, this indicates a hardware problem. Contact your HP support representative. You can obtain additional information by running the card selftest (through the SIC subcommand of the TermDSM RESET command), the DTC selftest, and the DTC offline diagnostics.

If this is an external loopback, check the loopback hood to verify that it is securely connected and on the correct port.



If this is a terminal loopback, verify that a supported, powered on terminal is securely connected to the proper port. Check baud rate, parity, etc. Note that the terminal configuration must match the configuration file, not the state the terminal was in when it was last used. If this does not help, run internal, then external loopback to discriminate between a DTC problem and a terminal/cabling problem.

**(TDSM 230) MESSAGE: Alternate end-of-record received. Time = xx msec. (TDSM 230)**

CAUSE: Probable hardware failure.

ACTION: Contact you HP support representative. You can obtain additional information by running the card selftest (through the SIC subcommand of the TermDSM RESET command), the DTC selftest, and the DTC offline diagnostics.

**(TDSM 231) MESSAGE: Subsystem break. Time = xx msec. (TDSM 231)**

CAUSE: Probable hardware failure.

ACTION: Contact you HP support representative. You can obtain additional information by running the card selftest (through the SIC subcommand of the TermDSM RESET command), the DTC selftest, and the DTC offline diagnostics.

**(TDSM 232) MESSAGE: No modem was connected during the operation. Time = xx msec. (TDSM 232)**

CAUSE: During the test, the modem on that port was disconnected.

ACTION: Reconnect the modem and try the test again. If the failure continues, or if there was no modem in use on that port, there is a probable hardware failure.

Contact your HP support representative. You can obtain additional information by running the card selftest (through the SIC subcommand of the TermDSM RESET command), the DTC selftest, and the DTC offline diagnostics.

**(TDSM 234) MESSAGE: Console attention. Time = xx msec. (TDSM 234)**

CAUSE: Probable hardware failure.

ACTION: Contact you HP support representative. You can obtain additional information by running the card selftest (through the SIC subcommand of the TermDSM RESET command), the DTC selftest, and the DTC offline diagnostics.

**(TDSM 235) MESSAGE: Operation aborted. (TDSM 235)**

CAUSE: The operation was aborted by the DTC. Possibly, the download file is invalid.

ACTION: Verify the version and integrity of the download file. Contact your HP support representative. You can obtain additional information by running the DTC selftest DTC selftest or the DTC offline diagnostic.

**(TDSM 240) MESSAGE: During a DTC reset/dump request from the mainframe. (TDSM 240)**

CAUSE: Informational message which can be printed after an error message. It describes in which phase of an operation the error occurred.

ACTION: Refer to the cause and action descriptions for the actual error message preceding message 240.

**(TDSM 241) MESSAGE: During the DTC download operation. (TDSM 241)**

CAUSE: Informational message which may be printed after an error message. It describes in which phase of an operation the error occurred.



**ACTION:** Refer to the cause and action descriptions for the actual error message preceding message 241.

**(TDSM 242) MESSAGE: During a DTC upload (dump) operation. (TDSM 242)**

**CAUSE:** Informational message which may be printed after an error message. It describes in which phase of an operation the error occurred.

**ACTION:** Refer to the cause and action descriptions for the actual error message preceding message 242.

**(TDSM 243) MESSAGE: Bad parameter from TermDSM. (TDSM 243)**

**CAUSE:** Internal error.

**ACTION:** Contact your HP support representative.

**(TDSM 244) MESSAGE: The TermDSM command resulted in an instruction being sent to a DTC, and the DTC did not respond.**

**CAUSE:** Timeout waiting for the DTC to respond. The DTC may be powered off, malfunctioning, or misconfigured. (TDSM 244)

**ACTION:** Note that the DTC list printed by TermDSM is only a list of the DTCs configured, not a list of installed, powered on, and working DTCs.

If the DTC in question was working, and no changes were made to the configuration file, ensure that the DTC is powered on. If so, this error indicates a probable hardware error. Contact your HP support representative.

If this is a new installation or DTC, which has never been run before, the above comments can still apply. However, if the configuration is incorrect, a functional DTC might still not respond. Check the configuration file, power to the DTC, connections, etc. If problems persist, contact your HP support representative.

This error can also be the result of a LAN problem. If other DTC(s) are working on the same LAN, the problem is probably related to the DTC or its configuration. If there is only one DTC, or other DTCs on the same LAN are unresponsive, then the LAN hardware or software might be at fault. The LAN diagnostic LANDAD can be run to investigate LAN problems.

**(TDSM 245) MESSAGE: Write to IEEE 802.3 DAM failed. (TDSM 245)**

**CAUSE:** Internal error.

**ACTION:** Contact your HP support representative.

**(TDSM 246) MESSAGE: This DTC is owned by another TermDSM. Possibly, your TermDSM was overridden by that TermDSM.**

**CAUSE:** Only one TermDSM session may be active at one time on a DTC. Possibly, another TermDSM session was started on the DTC and has overwritten your original TermDSM session.

**ACTION:** Find out who else is running TermDSM on the DTC. Coordinate your effort with the other user to avoid TermDSM session conflict.

**(TDSM 247) MESSAGE: Bad NMP packet received from DTC. (TDSM 247)**

**CAUSE:** Internal error.

**ACTION:** Contact your HP support representative.

**(TDSM 248) MESSAGE: The DTC requested to be downloaded during the operation. (TDSM 248)**

CAUSE: The DTC was trying to power up at the same time you were trying to access it.

ACTION: Wait for the download, or upload/download, to complete (as shown by the console messages). Verify then that the DTC is operational. If not, contact your HP support representative.

**(TDSM 249) MESSAGE: The DTC requested that it be dumped during the operation. (TDSM 249)**

CAUSE: The DTC detected an internal error at the same time you were trying to access it through TermDSM.

ACTION: Wait for the download, or upload/download, to complete (as shown by the console messages). Then verify if the DTC is operational. If not, contact your HP support representative.

**(TDSM 250) MESSAGE: DTC and host RMP versions are incompatible. (TDSM 250)**

CAUSE: Incompatibilities were found between subsystem software on the HP 3000 and subsystem software on the DTC.

ACTION: Contact your HP support representative.

**(TDSM 251) MESSAGE: Bad RMP packet received from DTC. (TDSM 251)**

CAUSE: Internal error.

ACTION: Contact your HP support representative.

**(TDSM 252) MESSAGE: Could not open the download or dump file. (TDSM 252)**

CAUSE: Files pertaining to this operation cannot be accessed.

ACTION: If this is a dump, verify that sufficient disk space exists to create the dump file. Approximately 2200 sectors of disk space is required. If enough disk space is available (or if you were not trying to perform a dump operation), contact your HP support representative.

**(TDSM 253) MESSAGE: Unable to get a system timer. (TDSM 253)**

CAUSE: Internal error.

ACTION: Contact your HP support representative.

**(TDSM 255) MESSAGE: Dump overflow: DTC sent more data than expected. (TDSM 255)**

CAUSE: Internal error.

ACTION: Contact your HP support representative.

**(TDSM 255) MESSAGE: Dump overflow: DTC sent more data than expected. (TDSM 255)**

CAUSE: Internal error.

ACTION: Contact your HP support representative.

**(TDSM 260) MESSAGE: Bad NMP error code received. (TDSM 260)**

CAUSE: Unknown error reported by the Distributed Terminal Subsystem to TermDSM.

ACTION: Contact your HP support representative.

**(TDSM 261) MESSAGE: Bad RMP return code received. (TDSM 261)**

CAUSE: Unknown error reported by the Distributed Terminal Subsystem to TermDSM.

ACTION: Contact your HP support representative.

- (TDSM 262) MESSAGE: The DTC subsystem has reported that an error was detected. Here is the specific message: (TDSM 262)**  
CAUSE: This is the standard message that precedes specific error messages.  
ACTION: Contact your HP support representative.
- (TDSM 263) MESSAGE: An error of unknown type was reported by the DTS subsystem. (TDSM 263)**  
CAUSE: An error unknown to TermDSM was reported by the Distributed Terminal Subsystem.  
ACTION: Contact your HP support representative.
- (TDSM 264) MESSAGE: The DTC reported an unknown status as a result of the loopback. Time taken=xx. (TDSM 264)**  
CAUSE: An error unknown to TermDSM was reported by the Distributed Terminal Subsystem.  
ACTION: Contact your HP support representative. You can obtain additional information by running the card selftest (through the SIC subcommand of the TermDSM RESET command), the DTC selftest, and the DTC offline diagnostics.
- (TDSM 266) MESSAGE: Please perform a DTC reset instead of board reset. (TDSM 266)**  
CAUSE: The DTC 16iX/16MX has only one board; resetting a board is the same as resetting a DTC.  
ACTION: Do a DTC reset instead of a board reset.
- (TDSM 267) MESSAGE: Please perform a DTC upload instead of board upload. (TDSM 267)**  
CAUSE: The DTC 16iX/16MX has only one board; uploading a board is the same as uploading a DTC.  
ACTION: Do a DTC upload instead of a board upload.
- (TDSM 268) MESSAGE: You have entered an incorrect ROM code version.)**  
CAUSE: Incorrect ROM code version was entered for EEPROM reprogramming.  
ACTION: Re-enter the correct ROM code version.
- (TDSM 268) MESSAGE: You have entered an incorrect ROM code version.)**  
CAUSE: Incorrect ROM code version was entered for EEPROM reprogramming.  
ACTION: Re-enter the correct ROM code version.
- (TDSM 270) MESSAGE: You have entered an incorrect ROM code version.)**  
CAUSE: The DTC has reported that the port in question is bad or does not exist.  
ACTION: Note the range of ports in the error message. If you are specified a port that does not exist, verify the information to determine the correct port. For reset and dump, you can specify an ldev number instead of the port to do the operation.  
  
If the port does exist, a hardware failure has probably occurred. Contact you HP support representative. You can obtain additional information by running the card selftest (through the SIC subcommand of the TermDSM RESET command), the DTC selftest, and the DTC offline diagnostics.
- (TDSM 271) MESSAGE: That SIC is malfunctioning, or not installed. TermDSM can not always tell the difference between 'not installed' and a serious malfunction. (TDSM 271)**

CAUSE: Possible hardware problem or no card is installed in that slot.

ACTION: Double check that the SIC number you specified is correct. If it is, it is likely that the SIC is defective. Contact you HP support representative. You can obtain additional information by running the card selftest (through the SIC subcommand of the TermDSM RESET command), the DTC selftest, and the DTC offline diagnostics.

**(TDSM 275) MESSAGE: The loopback is too long. (TDSM 275)**

CAUSE: Internal error.

ACTION: Contact you HP support representative.

**(TDSM 280) MESSAGE: Dump failed. Open of DTCM failed, or DTC owned and not overridden (TDSM 280)**

CAUSE: This message is written to dump files, and never appears as an error message to a user terminal.

If the user was informed the DTC was in use by another TermDSM (see message 35), and the second user chose NOT to override, then this message is normal and is not cause for alarm. Otherwise, it is indicative of an internal error

ACTION: If the problem persists, take another dump. If you are sure another user was not involved, contact your HP support representative.

**(TDSM 281) MESSAGE: Dump failed: Send or Receive of dump request failed. (TDSM 281)**

CAUSE: An internal error. This message is written to dump files and never appears as an error message to a user.

ACTION: Contact you HP support representative.

**(TDSM 282) MESSAGE: Dump failed: Bad function in internal error reply to dump request.(TDSM 282)**

CAUSE: An internal error. This message is written to dump files and never appears as an error message to a user.

ACTION: Contact you HP support representative.

**(TDSM 283) MESSAGE: Dump failed. Bad reply (Ilio) status from DTCM. (TDSM 283)**

CAUSE: An internal error.

ACTION: Contact you HP support representative.

**(TDSM 290) MESSAGE: Sorry, TermDSM does not provide services for the console. (TDSM 290)**

CAUSE: The user entered the ldev number of the physical console for a reset or dump. TermDSM cannot act upon the physical console port because it is not on the DTC. TermDSM can only operate on ldev numbers and ports that are on the DTC.

Note: The discussion here is for the physical console, not a terminal which has taken control of the logical console via the CONSOLE command.

ACTION: Contact you HP support representative.

**(TDSM 303) MESSAGE: Unknown download file requested in RMP packet. (TDS M303)**

CAUSE: An internal error.

ACTION: Contact you HP support representative.

**(TDSM 307) MESSAGE: Boot (download) complete message received before expected. (TDSM 307)**

CAUSE: It has finished the download of its operating firmware before the DTCM expected it.

ACTION: Look on the console for a “boot complete” message. Otherwise, enter the command again. If the problem persists, contact your HP support representative.

- (TDSM 308) MESSAGE: Unable to get an LLIO message frame. (TDSM 308)**  
 CAUSE: Internal error.  
 ACTION: Contact your HP support representative.
- (TDSM 309) MESSAGE: DTCM produced an unknown action code. (TDSM 309)**  
 CAUSE: Internal error.  
 ACTION: Contact your HP support representative.
- (TDSM 317) MESSAGE: Unable to get an outbound packet buffer. (TDSM 317)**  
 CAUSE: Internal error.  
 ACTION: Contact your HP support representative.
- (TDSM 318) MESSAGE: Unable to write to an outbound packet buffer. (TDSM 318)**  
 CAUSE: Internal error.  
 ACTION: Contact your HP support representative.
- (TDSM 319) MESSAGE: Unable to send an LLIO message. (TDSM 319)**  
 CAUSE: Internal error.  
 ACTION: Contact your HP support representative.
- (TDSM 320) MESSAGE: DTCM encountered an unspecified error. (TDSM 320)**  
 CAUSE: Internal error.  
 ACTION: Contact your HP support representative.
- (TDSM 321) MESSAGE: DTCM captured an unknown escapecode. (TDSM 321)**  
 CAUSE: Internal error.  
 ACTION: Contact your HP support representative.
- (TDSM 322) MESSAGE: DTC configuration file too large for buffer. (TDSM 322)**  
 CAUSE: Internal error.  
 ACTION: Contact your HP support representative.
- (TDSM 323) MESSAGE: Please reset or dump the specific PAD VC from ldev option. (TDSM 323)**  
 CAUSE: The user attempted to reset or dump a PAD VC using the VC subcommand. PAD connections can only be dumped or reset from the Ldev subcommand.  
 ACTION: Determine the ldev number that is associated with the PAD connection and retry the reset or dump operation using the Ldev subcommand.
- (TDSM 324) MESSAGE: The system is a HOST BASED X25. However the specified DTC has no SNP card. (TDSM 324)**  
 CAUSE: There is no DTC/X.25 XL Network Access (SNP) card mounted in the DTC that you specified in the TermDSM command.

**ACTION:** Verify the number that TermDSM associated with the DTC containing the DTC/X.25 XL Network Access card. Reenter the command with the correct DTC number specified.

**(TDSM 325) MESSAGE: Some other DTC is already tracing. (TDSM 325)**

**CAUSE:** Only one DTC can be tracing at a time.

**ACTION:** Turn off tracing on the other DTC and try again.

**(TDSM 326) MESSAGE: This requested DTC is already tracing. (TDSM 326)**

**CAUSE:** Tracing has already been turned on for the specified DTC.

**ACTION:** None required.

**(TDSM 327) MESSAGE: This DTC is not tracing. (TDSM 327)**

**CAUSE:** Tracing is turned off on the specified DTC.

**ACTION:** Turn on tracing for the specified DTC.

**(TDSM 328) MESSAGE: Invalid board number — out of range. (TDSM 328)**

**CAUSE:** The specified board number does not exist.

**ACTION:** Check the board installed in the DTC and re-specify the correct board number.

**(TDSM 329) MESSAGE: Indicated board is absent or is not an SNP card. (TD SM329)**

**CAUSE:** The board specified does not exist in the DTC or is not an SNP card.

**ACTION:** Verify that the required board is in the DTC. If you are trying to configure an SNP board, verify that the board you specified is an SNP board.

**(TDSM 330) MESSAGE: Trace file could not be opened. (TDSM 330)**

**CAUSE:** The file where tracing messages are logged could not be opened.

**ACTION:** Contact your HP support representative.

**(TDSM 331) MESSAGE: X.25 has not been started on indicated SNP card. (TDSM 332)**

**CAUSE:** The specified SNP card has not had X.25 started up on it.

**ACTION:** Contact your HP support representative.

**(TDSM 332) MESSAGE: X.25 is not configured for indicated SNP card. (TDSM 331)**

**CAUSE:** The indicated SNP card does not have X.25 configured for it.

**ACTION:** Contact your HP support representative.

**(TDSM 333) MESSAGE: X.25 or X.25/PADSUP not stopped. (TDSM 333)**

**CAUSE:** The operation you attempted required that X.25 or X.25/PADSUP be stopped and it was still running.

**ACTION:** Start up X.25 on the specified card and try again or specify a card that has X.25 started.

**(TDSM 334) MESSAGE: DTCM reports unexpected SIC UPLOAD request. (TDS M334)**

**CAUSE:** Internal error.

**ACTION:** Contact your HP representative.

**(TDSM 335) MESSAGE: This port is already under extended trace. (TDSM 335)**

CAUSE: Informational message.

ACTION: Issue the TRACESHOW command to see which ports on the DTC are currently under extended trace.

**(TDSM 336) MESSAGE: Another port on this MUX is already under extended trace. (TDSM 336)**

CAUSE: Only one port on an asynchronous processor board (mux card) can have extended trace at one time.

ACTION: Turn off extended tracing on a traced port before activating extended tracing on another port on the same asynchronous processor board.

**(TDSM 337) MESSAGE: No port on this MUX is under extended trace. (TDSM 337)**

CAUSE: Informational message.

ACTION: You may issue the TRACEON command to activate extended tracing on any port on this asynchronous processor board (mux card).

**(TDSM 338) MESSAGE: DTCM reports that DTC reset is not complete yet. (TDS M338)**

CAUSE: A TermDSM command has been issued against a DTC that is currently undergoing selftest.

ACTION: A DTC selftest may take up to seven minutes. Wait for this duration before issuing a TermDSM command against the DTC.

**(TDSM 339) MESSAGE: This is not a DTC 72MX, DTC 16iX, or DTC 16MX. (TDSM 339)**

CAUSE: A TermDSM command that is only valid for DTC 72MX/16iX/16MX is issued against a DTC 16 or DTC 48.

ACTION: Do not use this TermDSM command on a DTC 16 or DTC 48.

**(TDSM 340) MESSAGE: This is not a MUX board. (TDSM 340)**

CAUSE: A TermDSM command that is only valid for asynchronous processor boards (MUX board) on DTC 72MX is issued against a wrong type of card.

ACTION: Verify that you have specified the right DTC number and board number on the DTC. Only asynchronous processor boards on DTC 72MX can accept this TermDSM command.

**(TDSM 341) MESSAGE: The DTC is not up during showtrace on a MUX board. (TDSM 341)**

CAUSE: A TRACESHOW command has been issued against a DTC that is not up.

ACTION: Verify that you have specified that right DTC number. The DTC must be up in order for a TRACESHOW to list ports with extended tracing.

**(TDSM 342) MESSAGE: You cannot reset a LAN board. (TDSM 342)**

CAUSE: A RESET MUX command was issued against a LAN board on a DTC 72MX.

ACTION: Verify the board number in the RESET MUX command. You cannot reset a LAN board on a DTC 72MX. You can only reset asynchronous processor boards (mux cards on a DTC 72MX).

**(TDSM 343) MESSAGE: Hardware loopback is not supported on a DTC 72MX, DTC 16iX, or DTC 16MX. (TDSM 343)**

CAUSE: A hardware loopback was issued against a DTC 72MX, DTC 16iX, or DTC 16MX. Hardware loopback is only supported on DTC 16 and DTC 48.



**ACTION:** Verify the DTC number on the TermDSM command. Make sure the DTC is a not a DTC 72MX, DTC 16iX, or DTC 16MX.

**(TDSM 400) MESSAGE: The DTC returned an NMP error code of !. (TDSM 400)**

**CAUSE:** Internal error.

**ACTION:** Contact your HP support representative.

**(TDSM 401) MESSAGE: The DTC reported an NMP version mismatch. (TDSM 401)**

**CAUSE:** Internal error.

**ACTION:** Contact your HP support representative.

**(TDSM 402) MESSAGE: The DTC reported an NMP token error or unknown VC number during DUMP. (TDSM 402)**

**CAUSE:** Internal error.

**ACTION:** Contact your HP support representative.

**(TDSM 403) MESSAGE: The DTC reported an NMP bad port. (TDSM 403)**

**CAUSE:** Internal error.

**ACTION:** Contact your HP support representative.

**(TDSM 404) MESSAGE: The DTC reported an NMP loopback aborted. (TDSM 404)**

**CAUSE:** Internal error.

**ACTION:** Contact your HP support representative.

**(TDSM 405) MESSAGE: The DTC reported an NMP loopback modem error. (TDSM 405)**

**CAUSE:** Internal error.

**ACTION:** Contact your HP support representative.

**(TDSM 406) MESSAGE: The DTC reported an NMP loopback time out. (TDSM 406)**

**CAUSE:** Internal error.

**ACTION:** Contact your HP support representative.

**(TDSM 407) MESSAGE: The DTC reported an UNKNOWN VC number. (TDSM 407)**

**CAUSE:** Internal error.

**ACTION:** Contact your HP support representative.

**(TDSM 450) MESSAGE: The DTC returned an RMP error code of !. (TDSM 450)**

**CAUSE:** Internal error.

**ACTION:** Contact your HP support representative.

**(TDSM 451) MESSAGE: The DTC reported an RMP version mismatch. (TDSM 451)**

**CAUSE:** Internal error.

**ACTION:** Contact your HP support representative.

**(TDSM 452) MESSAGE: The DTC reported an RMP token error. (TDSM 452)**

**CAUSE:** Internal error.

**ACTION:** Contact your HP support representative.



- (TDSM 500) MESSAGE: The DTC reported a SIC board not up. (TDSM 500)**  
 CAUSE: The serial interface card (SIC) in the DTC is not working.  
 ACTION: Contact your HP support representative.
- (TDSM 590) MESSAGE: The Ilio error occurred when TERMDSM tried to get SYSBASE. (TDSM 590)**  
 CAUSE: Internal Error.  
 ACTION: Contact your HP support representative.
- (TDSM 591) MESSAGE: The system is PC BASED. TERMDSM doesn't support PC BASED. (TDSM 591)**  
 CAUSE: The user attempted to run TermDSM on a system managed by the OpenView DTC Manager. Such systems are said to be "PC-based," and TermDSM is not supported on PC-based systems.  
 ACTION: See the manual titled *Using HP OpenView DTC Manager* for information on obtaining diagnostic information for terminal and printer connections on PC-based systems.
- (TDSM 592) MESSAGE: The system is HOST BASED TIO. TERMDSM only supports X25 functions on HOST BASED X25. (TDSM 592)**  
 CAUSE: The user entered an X.25 diagnostic command while running TermDSM on a host-based system that is not configured to support X.25 connections. X.25 commands are not available on systems that support terminal (TIO) I/O only.  
 ACTION: None. (Consult this manual to determine which TermDSM commands are supported on host-based systems configured for TIO only.)
- (TDSM 604) MESSAGE: You have entered an invalid SNP card number. SNP card numbers range from 0 to 5. (TDSM 604)**  
 CAUSE: The user entered an invalid number when asked to specify the card number of the DTC/X.25 Network Access card (SNP card).  
 ACTION: Enter the number of the DTC slot that contains the SNP card on which you want the TermDSM command to operate. SNP cards are allowed in slots 0 through 3 for DTC 72MX, slots 1 through 5 for DTC 48, and 2 for DTC 16; therefore, the valid range for the SNP card number is 0 through 5.  
 For example, to execute a `DUmp` command for an SNP card contained in slot 3 of the DTC designated as DTC #1, you would enter the following subcommand at the `DUmp` subcommand prompt:  
 SN 1,3
- (TDSM 605) MESSAGE: The SNP card number is missing or invalid. SNP card numbers range from 0 to 5. (TDSM 605)**  
 CAUSE: The user entered a TermDSM subcommand specifying the `SNp` option but did not specify a valid DTC/X.25 Network Access card (SNP) number.  
 ACTION: Reenter the subcommand specifying a valid card number for the SNP card. The SNP card number corresponds to the slot number in the DTC where the card is contained. The valid range of SNP card numbers is 0 to 3 for DTC 72MX, 1 through 5 for DTC 48, and 2 for DTC 16.

For example, to execute a `DUmp` command for an SNP card contained in slot 3 of the DTC designated as DTC #1, you would enter the following subcommand at the `DUmp` subcommand prompt:

```
SN 1,3
```

**(TDSM 606) MESSAGE: You have entered a bad VC number. VC numbers range from 0 to 4095. (TDSM 606)**

**CAUSE:** The user entered an invalid number when asked to specify the VC number associated with the virtual circuit on which the TermDSM function is to be performed.

**ACTION:** Enter the number that corresponds to the VC on which the TermDSM function is to be performed. Valid numbers range from 0 to 4095.

**(TDSM 607) MESSAGE: The VC number is missing or invalid. VC numbers range from 0 to 4095. (TDSM 607)**

**CAUSE:** The user entered a TermDSM subcommand specifying the VC option but did not specify a valid VC (virtual circuit) number.

**ACTION:** Reenter the subcommand specifying a valid VC number. Virtual circuits may be numbered from 0 through 4095.

For example, to execute a `DUmp` command for VC #15 active on an SNP card in slot 3 of DTC #1, you would enter the following subcommand at the `DUmp` subcommand prompt:

```
V 1,3,15
```

**(TDSM 608) MESSAGE: You have entered an invalid X25 address. The X25 address may be up to 15 digits from 0 to 9. (TDSM 608)**

**CAUSE:** The user entered an invalid X.25 address during execution of the `XNetwork` subcommand of the `DIAg` function of TermDSM.

**ACTION:** Determine the correct X.25 destination address as configured on the Level 3 Configuration screen in NMMGR. Reenter the `XNetwork` subcommand using the correct X.25 address.

For example, to perform a loopback for an SNP card contained in slot 3 of the DTC designated as DTC #1, with a destination address configured as 345678, you would enter the following subcommand at the `DIAg` subcommand prompt:

```
XN 1,3,345678
```

**(TDSM 609) MESSAGE: The X25 address is missing or invalid. The X25 address may be up to 15 digits from 0 to 9. (TDSM 609)**

**CAUSE:** The user failed to enter a valid X.25 address during execution of the `XNetwork` subcommand of the `DIAg` function of TermDSM.

**ACTION:** Determine the correct X.25 destination address as configured on the Level 3 Configuration screen in NMMGR. Reenter the `XNetwork` subcommand using the correct X.25 address.

For example, to perform a loopback for an SNP card contained in slot 3 of the DTC designated as DTC #1, with a destination address configured as 345678, you would enter the following subcommand at the `DIAg` subcommand prompt:

```
XN 1,3,345678
```

**(TDSM 610) MESSAGE: You have entered a bad X25 status option. X25 status options range from 1 to 4. (TDSM 610)**

CAUSE: The user entered an invalid status option for the `SNP` subcommand of the `TermDSM STATUS` function.

ACTION: Reenter the subcommand using one of the valid status options, as follows:

1 = Global

2 = Level 2

3 = Level 3

4 = PAD

For example, to obtain information about the status of PAD support on an SNP card contained in slot 3 of the DTC designated as DTC #1, you would enter the following subcommand at the `status` subcommand prompt:

SN 1,3,4

(TDSM 611)

**MESSAGE: The X25 status option is missing or invalid. X.25 status options range from 1 to 4. (TDSM 611)**

CAUSE: The user failed to enter a valid status option for the `SNP` subcommand of the `TermDSM STATUS` function.

ACTION: Reenter the subcommand using one of the valid status options, as follows:

1 = Global

2 = Level 2

3 = Level 3

4 = PAD

For example, to obtain information about the status of PAD support on an SNP card contained in slot 3 of the DTC designated as DTC #1, you would enter the following subcommand at the `status` subcommand prompt:

SN 1,3,4

(TDSM 612)

**MESSAGE: You have entered a bad X25 trace option. X25 trace options range from 1 to 3. (TDSM 612)**

CAUSE: The user entered an invalid trace option for the `TermDSM TRACEON` function.

ACTION: Reenter the command using one of the valid trace options, as follows:

1 = VC

2 = Level 2

3 = Level 3

For example, to turn on a level 2 trace for an SNP card contained in slot 3 of the DTC designated as DTC #1, you would enter the following:

TRACEON 1,3,2

(TDSM 613)

**MESSAGE: The X25 trace option is missing or invalid. X25 trace options range from 1 to 3. (TDSM 613)**

CAUSE: The user failed to enter a valid trace option for the `TermDSM TRACEON` function.

ACTION: Reenter the command using one of the valid trace options, as follows:

1 = VC

2 = Level 2

3 = Level 3

For example, to turn on a level 2 trace for an SNP card contained in slot 3 of the DTC designated as DTC #1, you would enter the following:

```
TRACEON 1,3,2
```

- (TDSM 614) MESSAGE: You have entered a bad linkname. X25 linkname may be up to 8 ASCII characters. (TDSM 614)**
- CAUSE: During execution of the TRACEON function, the user entered an invalid linkname.
- ACTION: Enter a valid linkname for the trace file. This is the linkname as configured in NMMGR and can be up to 8 ASCII characters.
- (TDSM 615) MESSAGE: The X25 linkname is missing or invalid. X25 linkname may be up to 8 ASCII characters. (TDSM 615)**
- CAUSE: During execution of the TRACEON function, the user failed to enter a valid X.25 linkname.
- ACTION: Enter a valid file name for the trace file. The file name can be up to 8 alphanumeric characters and must start with a letter.
- (TDSM 617) MESSAGE: TRACE will be used as X25 trace filename by default. (TDSM 617)**
- CAUSE: During execution of the TRACEON function, the user pressed the carriage return when prompted for a trace file name.
- ACTION: None. This message is for information only.
- (TDSM 618) MESSAGE: There is no TRACE in progress. (TDSM 618)**
- CAUSE: The user entered a TRACEOFF command to stop a trace but there was no trace active.
- ACTION: None. This message is for information only.
- (TDSM 619) MESSAGE: You have entered an incorrect Network number. Please choose a "Netwk#" from this list: (TDSM 619)**
- CAUSE: The network number entered is not a valid network number from the list or is for the console.
- ACTION: Termdsm will redisplay the X.25 Active Site network map. Chose the correct network number from the list.
- (TDSM 620) MESSAGE: The Network number is missing or invalid. Please choose a "Netwk#" from this list: (TDSM 620)**
- CAUSE: The parameter entered with the LIST command is not a valid number.
- ACTION: Termdsm will redisplay the X.25 Active Site network map. Reenter the LIST command with the correct number.
- (TDSM 630) MESSAGE: You have entered an invalid ROM version. The ROM version is made up of 8 ASCII characters. (TDSM 630)**
- CAUSE: During execution of the reprogramming EEPROM process, the user entered an invalid ROM version.
- ACTION: Enter a valid ROM version for the reprogramming EEPROM process.

- (TDSM 631) MESSAGE: The ROM version is missing or invalid. The ROM version is made up of 8 ASCII characters. (TDSM 631)**
- CAUSE: During execution of the reprogramming EEPROM process, the user failed to enter a ROM version or entered an invalid ROM version.
- ACTION: Enter a valid ROM version for the reprogramming EEPROM process.
- (TDSM 634) MESSAGE: TermDSM did not set the DTC to IDLE during EEPROM reprogramming. (TDSM 634)**
- CAUSE: Internal error.
- ACTION: Contact your HP support representative.
- (TDSM 635) MESSAGE: The EEPROM reprogramming was successfully completed. (TDSM 635)**
- CAUSE: This message is for information only.
- ACTION: None. This message is for information only.
- (TDSM 636) MESSAGE: The EEPROM reprogramming process is executing. The process takes about 7–10 minutes. Warning: Interrupting the process can be fatal to the DTC. (TDSM 636)**
- CAUSE: Warning message.
- ACTION: None. This message is for information only.
- (TDSM 637) MESSAGE: TermDSM will now reprogram EEPROM with version XXX. (TDSM 637)**
- CAUSE: If you continue, all user sessions on this DTC will be aborted.
- ACTION: If you want to continue, you should alert all the users that their sessions will be aborted.
- (TDSM 638) MESSAGE: Fatal error occurred during EEPROM reprogramming process. Please contact HP representative to recover the DTC. (TDSM 638)**
- CAUSE: Internal error.
- ACTION: Contact your HP support representative.
- (TDSM 680) MESSAGE: You have entered an invalid MUX board number. MUX board numbers range from 0 to 3. (TDSM680)**
- CAUSE: The MUX board number you have entered is not in the range from 0 to 3
- ACTION: Double check the MUX board number by looking at the back of the DTC 72MX. Enter the board number again. This TermDSM command is only supported for asynchronous processor boards on DTC 72MX.
- (TDSM 681) MESSAGE: The MUX board is missing or invalid. MUX board numbers range from 0 to 3. (TDSM 681)**
- CAUSE: The MUX board number was not entered or is unrecognizable.
- ACTION: Enter the MUX board number again. Refer to the prompt or Chapter 4, “TermDSM Commands,” for syntax. This command is only supported for asynchronous processor boards on DTC 72MX.
- (TDSM 682) MESSAGE: You have entered a bad port number. Port numbers range from 0 to 23. (TDSM 682)**
- CAUSE: The port number that you entered is not in the range from zero to 23.

**ACTION:** Double check the port number by looking at the device connection on the DTC. Enter the port number again. This command is only supported for ports on DTC 72MX.

**(TDSM 683) MESSAGE: The port number is missing or invalid. Port numbers range from 0 to 23. (TDSM 683)**

**CAUSE:** The port number was not entered or is unrecognizable.

**ACTION:** Enter the port number again. Refer to the prompt or Chapter 4, “TermDSM Commands,” for syntax. This command is only supported for ports on DTC 72MX.

**(TDSM 700) MESSAGE: Please put a loopback hood on the SNP card before answering the “How many times?” question. (TDSM 700)**

**CAUSE:** A loopback hood must be in place before the diagnostic is run.

**ACTION:** Place loopback hood on the SNP card and continue.

**(TDSM 701) MESSAGE: Please set up the environment for the network loopback test on the SNP card before answering the 'How may times?' question. (TDSM 701)**

**CAUSE:** Supported hardware must be present and ready before the diagnostic is run.

**ACTION:** Make the appropriate hardware ready and continue.

**(TDSM 720) MESSAGE: Termdsm could not open the DTC manager, so the SNP dump could not be obtained. (TDSM 720)**

**CAUSE:** Internal error, unless another TermDSM was being run against that same DTC and you chose not to override the other user. There is no error in this case.

**ACTION:** Contact you HP support representative (if it is an internal error).

**(TDSM 721) MESSAGE: Dump fail: Send or Receive of dump request failed. (TDS M721)**

**CAUSE:** Internal error.

**ACTION:** Contact you HP support representative.

**(TDSM 722) MESSAGE: Dump failed: Bad function in reply to dump request. (TDSM 722)**

**CAUSE:** Internal error.

**ACTION:** Contact you HP support representative.

**(TDSM 723) MESSAGE: Dump failed: Bad reply (Ilio) status from DTCM. (TDSM 723)**

**CAUSE:** Internal error.

**ACTION:** Contact you HP support representative.

**(TDSM 800) MESSAGE: Timeout (no response from the network). Verify the physical connection to the network, and ensure that the X25 address is correctly configured. (TDSM 800)**

**CAUSE:** A timeout occurred before TermDSM received a response from the network.

**ACTION:** Make sure all physical network connections are in place. If physical connections are OK, run NMMGR to verify that the X.25 address is correctly configured. If the problem persists, contact you HP support representative.

**(TDSM 801) MESSAGE: The call has been accepted by another node on the network. Verify the correct configuration of the X25 address. (TDS M801)**

**CAUSE:** The user was attempting to perform a loopback test, but the connection was accepted by a different node on the network. This could happen if the X.25 address configured for loopback belongs to a different system instead of the local system.

ACTION: Run NMMGR and correct the X.25 address configured for loopback on the level 3 configuration screen.

**(TDSM 802) MESSAGE: The call has been refused by the network. Verify the address configuration and the number of VCs configured. (TDS M802)**

CAUSE: The user was attempting to perform a loopback test on an SNP card but the network would not accept the call.

ACTION: Run NMMGR to correct any problems with the DTC/X.25 Network Access card (SNP card) configuration.

**(TDSM 803) MESSAGE: Bad card. (TDSM 803)**

CAUSE: The DTC/X.25 Network Access card (SNP) being tested is bad.

ACTION: Contact your HP support representative.

**(TDSM 804) MESSAGE: All ports are bad. (TDSM 804)**

CAUSE: All ports on the DTC/X.25 Network Access card (SNP) being tested are bad.

ACTION: Contact your HP support representative.

**(TDSM 805) MESSAGE: Some ports are bad. (TDSM 805)**

CAUSE: Some ports on the DTC/X.25 Network Access card (SNP) being tested are bad.

ACTION: Contact your HP support representative.

**MESSAGE: Unknown Cable. (TDSM 806)**

**(TDSM 806)**

CAUSE: TermDSM does not recognize the cable interfacing the DTC/X.25 Network Access card (SNP card) to the network.

ACTION: Replace cable with a supported network interface cable.





---

# Glossary

## A

**access port** A special interface card in the system cabinet through which the MPE/iX system console is connected.

**ADCP** Avesta Device Control Protocol. An HP proprietary protocol which provides device control features. ADCP is optimized for communications between a DTC and MPE/iX systems.

**address** A numerical identifier defined and used by a particular protocol and associated software to distinguish one node from another.

**address key** *See* **X.25 address key**.

**address resolution** In NS networks, the mapping of node names to IP addresses and the mapping of IP addresses to subnet addresses.

**address resolution protocol (ARP)** A protocol used to convert an IP address to a low level hardware address. ARP can be used only over a single physical network and is limited to networks that support hardware broadcast.

**adjacent** A node on a point-to-point network that is connected to another node by a single link with no intervening nodes.

**ADP** Active Distribution Panel. *See* **MDP**.

**AFCP** Avesta Flow Control Protocol. An HP proprietary protocol which provides data flow control features. AFCP is optimized for communications between nodes, including DTCs, in an MPE/iX environment.

**ARP** *See* **address resolution protocol**.

**ARPA** Advanced Research Projects Agency. It is the former name of the Defense Advanced Research Project Agency (DARPA). The Internet suite of protocols was developed under ARPA guidance.

**ARPA Telnet Access** An HP product which is a board that can be installed in a DTC 48 and DTC 72MX. The Telnet Access board performs protocol translation. Calls to the IP address of an MPE/iX system are detected by the Telnet Access board and are retransmitted on the LAN using AFCP, allowing connections from terminals on ARPA systems to HP 3000s.

**ARPA Telnet Express** An HP product which is a standalone hardware platform dedicated to performing protocol translation. Calls to the IP address of an MPE/iX system are detected by the Telnet Express and are retransmitted on the LAN using AFCP, allowing connections from terminals on ARPA systems to HP 3000s.

**ASCII** American National Standard Code for Information Interchange. A character set using 7-bit code used for information interchange among data processing and data communications systems. The American implementation of International Alphabet No. 5.

**asynchronous** A device's mode of operation in which a sequence of operations are executed irrespective of time coincidence with any event. Devices that are directly accessible by people (for example, terminal keyboards) operate in this manner.

**asynchronous processor board** The new 24-port mux board for the DTC 72MX. Allows up to 24 direct and modem connections per board. A DTC 72MX can have up to 3 asynchronous processor boards (for a total of 72 connections).

**asynchronous processor board** The new 24-port mux board for the DTC 72MX. Allows up to 24 direct and modem connections per board. A DTC 72MX can have up to 3 asynchronous processor boards (for a total of 72 connections).

**Attachment Unit Interface AUI**. The cable that runs between each node (host, DTC, or other device) and the Medium Attachment Unit (MAU) that connects it to the LAN in a ThickLAN configuration.

**autodial** A dial link in which the remote node's telephone number is automatically dialed by a modem or other device with this capability.

## B

**backbone LAN** A thick LAN cable conforming to the IEEE 802.3 Type 10 BASE 5 Standard.

**back-to-back configuration** A DTC configuration whereby MPE users connected to one DTC can communicate with a non-MPE/iX system connected to another DTC via the LAN. *See also* **Local Switching**.

**banner** A welcome message displayed on your screen. On the local OpenView workstation a banner appears when a remote connection is established with the OpenView DTC Manager. A banner also can appear when you log on to MPE.

**baud** The measure of the speed at which information travels between devices, most commonly used in reference to terminal speed settings. Baud represents signal events per second. When one bit represents each signal change, baud is the same as “bits per second.”

**binary mode** A data-transfer scheme in which no special character processing is performed. All characters are considered to be data and are passed through with no control actions being taken.

**bit** Binary digit. A unit of information that designates one of two possible states, which are represented by either 1 or 0.

**block mode** A terminal processing mode in which groups, or “blocks,” of data are transmitted all at once.

**BNC T-Connector** A connector used to connect a computer or a component such as a DTC to the LAN in a ThinLAN configuration.

**boundary** *See* **network boundary**.

**bps** Bits per second. The number of bits passing a point per second.

**bridge** A device that is used to connect LAN segments.

**broadcast** Communication method of sending a message to all devices on a link simultaneously.

**buffer** A logical grouping of a system’s memory resources used by NS 3000/iX.

**byte** A sequence of eight consecutive bits operated on as a unit.

## C

**call** In X.25, a call is an attempt to set up communication between two DTEs using a virtual circuit. Also known as a virtual call.

**call collision** A conflict that occurs at a DTE/DCE interface when there is a simultaneous attempt by the DTE and DCE to set up a call using the same logical channel identifier.

**called address** When a node sends out a call request packet, the packet contains the address of the destination node. The address of the destination node is the called address.

**calling address** When a node receives an incoming call packet, the packet contains the address of the sending node. The address of the sending node is the calling address.

**carrier** A continuous wave that is modulated by an information-bearing signal.

**catenet** *See* **internetwork**.

**CCITT** Consultative Committee for International Telephony and Telegraphy. An international organization of communication carriers, especially government telephone monopolies, responsible for developing telecommunication standards by making recommendations. The emphasis is on “recommendations”; no carrier is required to adhere to a CCITT recommendation, although most do so in their own interests.

**CIB** The channel input/output bus in the backplane of an HP 3000.

**circuit-switching network** A type of data communications network wherein a physical and exclusive link is maintained between two communicating devices for the call duration. An all-digital, circuit-switching network is often referred to as an X.21 network.

**closed user group** An X.25 user facility that allows communication to and from a pre-specified group of users and no one else.

**compatibility mode** A processing mode on HP 3000 Series 900 computers that allows applications written for MPE V/E-based systems to be ported and run without changes or recompilation.

**computer network** A group of computer systems connected in such a way that they can exchange information and share resources.

**configuration** 1) The way in which computer equipment is physically interconnected and set up to operate as a system. 2) The layout of the computer system, including the MPE table, memory, and buffer sizes, that tells which peripheral devices are (or can be) connected to the computer and how they can be accessed. 3) The process of defining the characteristics of a network in software.

For MPE/iX-based computers, the operating systems are configured through use of the SYSGEN utility.

Next, the Distributed Terminal Subsystem (DTS) link is configured by using NMMGR (running on the host) and can, in addition, be configured using the OpenView DTC Manager software (running on the OpenView Windows Workstation) depending on the type of network management you use.

A system that is to run network services (NS 3000/iX) is configured through use of NMMGR.

Access to X.25 is configured in two parts. The X.25 MPE/iX System Access software is configured on the host through use of NMMGR. The DTC/X.25 Network Access software residing on the DTC is configured at the OpenView Windows Workstation through use of the OpenView DTC Manager.

**configuration file** The configuration file contains the information that the network needs in order to operate. This file also contains information necessary for link-level and NetIPC logging. The only file name that the system recognizes is NMCONFIG.PUB.SYS.

**control-X echo** Three exclamation marks (! ! !) output to the terminal screen when the cancel character (normally [CTRL]-X) is entered.

**control-Y trap** A user-written procedure to which control is passed when the subsystem break character (normally [CTRL]-Y) is entered during execution of a program with subsystem break enabled.

**cross-validate** The process of assuring that information contained in two locations is consistent where it is imperative that it be consistent. For example, an automatic cross-validation occurs when you enter SYSGEN to assure that information contained in NMCONFIG.PUB.SYS agrees with system configuration data.

**CSMA/CD** Carrier Sense Multiple Access with Collision Detect, transmission access method used by the IEEE 802.3 LAN standard.

**CSN** *See* **circuit-switching network**.

**CTB** The cache transfer bus in the backplane of an HP 3000.

**CUG** *See* **closed user group**.

## D

**data** Basic elements of information that can be processed or produced by a computer.

### **Datacommunications and Terminal Controller**

*See* **DTC**.

**datagram** A self-contained packet that is independent of other packets. It does not require an acknowledgment and it carries information which is sufficient to route it from one DTE to another DTE without relying on earlier exchange between the DTEs.

**datagram** A self-contained packet that is independent of other packets. It does not require an acknowledgment and it carries information which is sufficient to route it from one DTE to another DTE without relying on earlier exchange between the DTEs.

**data overrun** Transmitted data that is sent faster than the receiving equipment can receive it. The resultant overflow data is lost. *See also* **flow control**.

**Datapac** The national public PSN of Canada.

**Datex-P** The national public PSN of West Germany.

**D bit** Delivery confirmation bit. Used in the X.25 protocol, the setting of the D bit in DATA packets indicates whether delivery acknowledgment of the packet is required from the local DCE or from the remote DTE. It therefore allows the choice between local and end-to-end acknowledgment.

**DCE** Data circuit-terminating equipment. The interfacing equipment required in order to interface to data terminal equipment (DTE) and its

transmission circuit. Synonyms: data communications equipment, dataset. A modem is an example of a DCE.

**DDX** The national public PSN of Japan.

**DDFA DTC Device File Access Utilities.** A set of HP-UX utilities which is used by systems and user written applications to programmatically access devices attached to DTC ports.

**DDP** Direct Distribution Panel; a distribution panel that serves as the electrical and physical interface between a DTC 72MX mux board (asynchronous processor board) and up to eight asynchronous devices for direct connections. *See* **MDP** for modem connections.

**dedicated printer** A printer that can be used only by one host on the LAN — the one specified in the Destination Node Name in that printer's configuration screen.

**demodulation** The process by which the information-bearing signal is retrieved from a modulated carrier wave. The inverse of modulation.

**destination node name** In DTS configuration, it is either 1) the name of a host that a user can be connected to by default (if switching is not enabled for that user, or if automatic modem connection is enabled), or 2) the name of the only host that can access a dedicated printer.

**device class** A collection of devices that have some user-defined relation. Device classes are assigned through use of the NMMGR configuration program.

**device-dependent characteristic** A file specification for which modifications are restricted because of the type of device on which the file is opened. For example, data directed to terminals must have a blocking factor of one.

**device driver** A software module that controls a specific type of input/output device.

**devicefile** A file being input to or output from any peripheral device except a disc. MPE/iX allows operations to be performed on the device itself as if it were a file.

**device independence** A characteristic of the operating system that allows users to selectively redirect input/output from a program, session, or job without regard to the nature of the device.

**device name** *See* **PAD name.**

**Dial ID protocol** A proprietary Hewlett-Packard protocol that provides security checking and address exchange for dial links.

**dial link** A connection made through public telephone lines.

**direct-connect device** An asynchronous device that is connected directly to a DTC through an RS-232-C or RS-422 cable, with no intervening communications equipment. Also referred to as a "local connection."

**direct connection** A leased line, private line, or other non-switched link in a network.

**direct dial** A dial link through which only one remote node can be reached.

**direct-path branching** The process of directly accessing any screen in NMMGR by entering a path name in the `Command:` field. The path name must be preceded by an at sign (@).

**download** The process of loading operating code and configuration files into the DTC's memory. The DTC is downloaded by the MPE/iX host for LANs using host-based network management, and by the PC for DTCs managed by the OpenView DTC Manager.

**driver** Software that controls input/output devices including NS 3000/iX links.

**DTC** Datacommunications and Terminal Controller. The DTC is a hardware device, configured as a node on a LAN, that enables asynchronous devices to access HP 3000 Series 900 computers. Terminals can either be directly connected to the DTC, or they can be remotely connected through a Packet Assembler Disassembler (PAD). The DTC can be configured with DTC/X.25 Network Access cards and DTC/X.25 Network Access software. A DTC/X.25 iX Network Link consists of two software modules: the X.25 iX System Access software (running on the host) and the DTC/X.25 Network Access software (running on the DTC).

**DTC 16** HP 2340A product. A DTC that provides 2 slots for asynchronous connections with each slot allowing up to 8 direct connections or 6 modem connections, plus an optional X.25 link supporting up to 32 virtual circuits.

**DTC 16iX** HP J2062A product. A DTC terminal server for HP 3000 systems. It allows up to 16 asynchronous connections to HP 3000 systems.

**DTC 16 MX** HP J2063A product. A DTC terminal server for HP 3000 and Telnet systems. It allows up to 16 asynchronous connections for the HP 3000 environment and for computer systems running ARPA, such as HP 9000s and third party systems.

When managed by the HP 3000, the DTC 16MX is configured and functions exactly like a DTC 16iX. The full functionality of the DTC 16MX is only available when it is managed by the OpenView DTC Manager.

**DTC 16TN** HP J2060A product. A DTC terminal server for Telnet systems. It allows up to 16 asynchronous connections to computer systems running ARPA, such as HP 9000s and third party systems.

**DTC 48** HP 2345B product. A DTC that provides 6 slots for asynchronous connections, X.25 links, or Telnet Access. Each slot allows up to 8 direct connections or 6 modem connections. A DTC 48 may have up to 3 slots used for X.25 links, each supporting up to 256 virtual circuits at speeds of up to 64 Kpbs or one Telnet Access card with 40 Telnet connections to HP 3000 Series 900 connections.

**DTC 72MX** HP J2070A product. A DTC that provides 3 slots allowing up to 72 asynchronous connections. Each slot accommodates up to 24 direct or modem connections. A DTC 72MX may have up to 3 slots used for X.25 links, each supporting up to 256 virtual circuits at speeds of up to 64 Kpbs. It may also use one slot for Telnet Access card with 40 Telnet connections to HP 3000 Series 900 computers.

**DTC identifier** An identifier used only within NMMGR to define the branch of the configuration file containing information about a particular DTC. The identifier must begin with a letter and can be up to eight characters long.

**DTC Manager** *See* **OpenView DTC Manager**.

**DTC node name** A unique name used to identify a DTC on a LAN. The node name format is nodename.domain.organization, with each of the three parts having up to 16 characters. The name begins with either a letter or a digit.

**DTC station address (802.3 address)** A 12-digit hexadecimal number used to identify the DTC as a node belonging to the network configuration. Also called the LAN address or node address.

**DTC switching** A facility enabling terminal users to select any host system that they want to connect to. DTC switching is available only when the OpenView DTC Manager is used for network management.

**DTC/X.25 Network Access** The software that resides on the Datacommunications and Terminal Controller (DTC). To configure access to an X.25 network, you must configure two software components: the X.25 iX System Access (residing on the HP 3000 host and configured through use of NMMGR software), and DTC/X.25 Network Access (configured on the OpenView Windows Workstation through use of the OpenView DTC Manager software for PC-based management, and through NMMGR for host-based management).

**DTC/X.25 Network Access card** The hardware card and channel adapter that provides X.25 Network Access. It resides in the Datacommunications and Terminal Controller (DTC).

**DTC/X.25 iX Network Link** Software and hardware that provides MPE/iX access to private and public X.25 networks. The X.25 iX System Access software resides on an HP 3000 host and is configured through use of NMMGR. The DTC/X.25 Network Access software resides on the Datacommunications and Terminal Controller and is configured at the OpenView Windows Workstation for PC-based management and through NMMGR for host-based management.

**DTE** Data Terminal Equipment. Equipment that converts user information into data-transmission signals or reconverts received data signals into user information. Data terminal equipment operates in conjunction with data circuit-terminating equipment.



**DTS** Distributed Terminal Subsystem. This consists of all of the Datacommunications and Terminal Controllers (DTCs) on a LAN, their LANIC cards (attached to the host), the LAN cable, and the host and DTC software that controls all related DTS hardware.

**duplex** A transmission method that allows two-way communication. If both ends of the transmission link can transmit simultaneously, it is called full duplex. If only one end can transmit at a time, it is half-duplex transmission.

## E

**EEPROM** Electrically Erasable Programmable Read-Only Memory. EEPROM reprogramming is used to replace a current DTC's ROM code that resides on the LAN board. The process is also referred to as Flash EEPROM reprogramming.

**entry priority** In a point-to-point network, it is a ranking that identifies the most desirable route for data to travel from a given local node to a remote node.

**entry priority** In a point-to-point network, it is a ranking that identifies the most desirable route for data to travel from a given local node to a remote node.

**environment** A session that is established on a remote node.

**escape from data transfer character** A character that allows a user who is connected to a host system through the DTC, to break that connection and return to the DTC switching user interface. The default is [CTRL]-K. This character is used only on networks managed by the OpenView Windows Workstation.

**escape sequence** A sequence of characters beginning with the escape character and followed by one or more other characters, used to convey control directives to printers, plotters, or terminals.

**Ethernet** A Local Area Network system that uses baseband transmission at 10 Mbps over coaxial cable and unshielded twisted pair. Ethernet is a trademark of Xerox Corporation.

**event log** One of three circular files stored on the OpenView windows workstation. It contains lists of events that are reported by the DTCs for which it is responsible.

## F

**facility** An optional service offered by a packet switching network's administration and requested by the user either at the time of subscription for network access or at the time a call is made. Also known as user facility.

**facility set** A facility set defines the various X.25 connection parameters and X.25 facilities that can be negotiated for each virtual circuit on a per-call basis.

**fast select** An optional packet-switching network facility by which user data can be transmitted as part of the control packets that establish and clear a virtual connection.

**FCS** Frame Check Sequence. A sequence of bits generated by X.25 at Level 2 that forms part of the frame and guarantees the integrity of its frame's contents. The FCS is also used by the IEEE 802.3 protocol to check the validity of frames.

**file equation** An assignment statement used to associate a file with a specific device or type of device during execution of a program.

**file number** A unique number associated with a file when the file is opened. The file number is returned in the FOPEN or HPFOPEN call used to open the file. It can be used to access that file until the file is closed.

**file specification** The name and location of a file. The full specification for a file includes the file name, group, and account.

**file system** The part of the operating system that handles access to input/output devices (including those connected through the DTC), data blocking, buffering, data transfers, and deblocking.

**Flash EEPROM** *See* EEPROM.

**flow control** A means of regulating the rate at which data transfer takes place between devices to protect against data overruns.

**flow control negotiation** One of the network subscribed facilities selected at subscription time. This facility allows the Flow Control parameter to be negotiated at call set-up time, as opposed to having a predefined value.

**formal file designator** A name that can be used programmatically or in a file equation to refer to a file.

**FOS** Fundamental Operating System. The programs, utilities, and subsystems supplied on the Master Installation Tape that form the basic core of the MPE/iX operating system.

**full gateway** A full gateway is a node that belongs to more than one network and has one IP address for each network. It uses store and forward to transfer packets between each network that it belongs to.

## G

**gateway** A node that connects two dissimilar network architectures. A gateway can be either a single node (full gateway) or two gateway halves.

**gateway half** A node that works in conjunction with another node on another network to form an internetwork. The only protocol used by gateway halves is the NS Point-to-Point 3000/iX Link. *See also full gateway.*

**gateway half link** A link between the two nodes of a gateway-half pair. Each of the two nodes of a gateway-half pair has a configured link (hardware interface card) that is used for the gateway half network interface. The NS Point-to-Point 3000/iX Link is the only link that can be used as a gateway-half link.

**gateway half pair** A set of two nodes that are joined by a gateway-half link. Each node in the pair must have a gateway-half network interface configured, using the link.

**Guided Configuration** A method of configuring a node in which a subset of the complete NMMGR interface is presented, and defaults of configurable values are used automatically.

## H

**handshaking** A communications protocol between devices or between a device and the CPU. Provides a method of determining that each end of a communications link is ready to transmit or receive data, and that transmission has occurred without error.

**hardware handshake** Uses modem signals CTS and RTS to pace the data transfer from the DTC to the attached device. (For DTC 72MX only.)

**hop count** See **internet hop count and intranet hop count.**

**host-based network management** A method of managing asynchronous communications for HP 3000 Series 900 computers. All of the control software is configured on a single MPE/iX host and is downloaded to the DTCs that are managed by that host. With host-based management, a permanent relationship exists between each DTC and the host. Terminal users can access only the single MPE/iX system that owns the DTC their terminal is connected to.

**host computer** The primary or controlling computer on a network. The computer on which the network control software resides. For HP purposes, it can also be used to distinguish the MPE/iX system (host) from the DTC.

**HP block mode** A block mode transmission method employed by HP computers where the system controls the block mode handshake. When HP block mode is used, the user program need not concern itself with data transfer protocol.

**HP ARPA Telnet Express** A DTC dedicated to providing protocol conversion between telnet on TCP/IP and AFCP to allow incoming calls from the ARPA environment to HP 3000 systems.

**HP PPN** Hewlett-Packard Private Packet Network. Hewlett-Packard's own packet-switching X.25 network, which gives users full control over the administration and security of their data communication.

**HP TS8** A terminal server that can support up to eight asynchronous serial connections. When used in back-to-back configuration, users can access HP 3000 MPE/V systems on it through a DTC.

**I**

**idle device timeout** A timeout defined by the Configure:CPU command. When the timer lapses, a device connected to the DTC user interface that is still inactive will be disconnected.

**IEEE 802.3** A standard for a broadcast local area network published by the Institute for Electrical and Electronics Engineers (IEEE). This standard is used for both the ThinLAN and ThickLAN implementations of the LAN.

**IEEE 802.3 multicast address** A hexadecimal number that identifies a set of nodes. This address is used for multicast delivery.

**IEEE 802.3 nodal address** A unique hexadecimal number that identifies a node on an IEEE 802.3 LAN.

**initialization string** A sequence of control characters used to initialize a terminal, printer, or plotter when a connection is established from a host on the network.

**INP** Intelligent Network Processor. The card residing in the back of an MPE V-based node that provides a point-to-point or X.25 interface.

**interactive communications** Processing that allows users to enter commands and data at the terminal and receive an immediate response. Interactive processing occurs in session mode on MPE/iX systems.

**internet communication** Communication that occurs between networks.

**internet hop count** The number of full gateways plus the number of gateway-half links that a packet must pass through in moving from source node to destination.

**Internet Protocol** A protocol used to provide routing between different local networks in an internetwork, as well as among nodes in the same local network. The Internet Protocol corresponds to Layer 3, the Network Layer, of the OSI model. *See also IP address.*

**Internet routing** Internet routing involves all the processes required to route a packet from a node on one network to a destination node on another network.

**Internetwork** Two or more networks joined by gateways.

**intranet communication** Communication that occurs between nodes in a single network.

**intranet hop count** The number of intermediate nodes that lie between a source and destination node on the same point-to-point network.

**intranet routing** Intranet routing involves all the processes required to route a packet from one node in a network to another node in the same network.

**intrinsic** A system routine accessible by user programs. It provides an interface to operating system resources and functions. Intrinsic routines perform common tasks such as file access and device control.

**IP** *See Internet Protocol.*

**IP address** Internet Protocol address. An address used by the Internet Protocol to perform internet routing. A complete IP address consists of a network portion and a node portion. The network portion of the IP address identifies a network, and the node portion identifies a node within the network.

**IP router** A node in an IP network that connects two or more networks and provides address mapping between them. The router selects messages from incoming buffers and places them into the appropriate outgoing message queues.

**ISO** International Organization of Standards. An international federation of national standards organizations involved in developing international standards, including communication standards.

**L**

**LAN** Local Area Network. A collection of data communication systems sharing a common cable whereby each system can communicate directly with another.

**LAN address** *See DTC station address.*

**LANIC** *See Local Area Network Interface.*



**LANIC physical path** The physical location (slot number) of the LANIC within the SPU.

**LANIC Self-Test** A ROM-based program on a LANIC card that tests and reports the status of the LANIC hardware.

**LAP** Link Access Protocol. The data link protocol specified by older versions (prior to 1980) of X.25 at Level 2 but still permitted and therefore usable. All new implementations of X.25 must use LAP-B, and all old implementations must migrate to LAP-B at a future date.

**LAP-B** Link Access Protocol -Balanced. The data link protocol specified by the 1980 version of X.25 at Level 2 that determines the frame exchange procedures. LAP-B must also be used over direct-connect NS Point-to-Point 3000/iX Links.

**LCI** Logical Channel Identifier. Local value on a network node which identifies the channel used to establish a virtual circuit (SVC or PVC) through an X.25 network.

**ldev** *See* **logical device number**.

**leased line** A data-grade telephone line leased directly to a subscriber and allocated specifically for the subscriber's needs.

**line speed** The speed at which data is transferred over a specific physical link (usually measured in bits or kilobits per second).

**link name** A name that represents a hardware interface card. The link name can contain as many as eight characters. All characters except the first can be alphanumeric; the first character must be alphabetic.

**Local Area Network Interface Controller (LANIC)** A hardware card that fits into the backplane of the HP 3000 Series 900 computer and provides a physical layer interface for IE E E802.3 local area networks.

**local connection** *See* **direct connection**.

**local node** The computer that you are configuring or that you are logged on to.

**local switching** A feature of the DTC which permits back-to-back configuration (for connections to an HP 3000 MPE/V host), using two ports of the same DTC.

**logging** The process of recording the usage of network resources. Events can be logged to both the OpenView workstation and to the MPE/iX host.

**logging class** A number defining the severity of any given event logged. An operator uses the logging classes to specify which events are to be logged. Class 1 (catastrophic event) is always logged.

**logical device number (ldev)** A value by which MPE/iX recognizes a specific device. All DTC devices that are configured as nailed devices through the NMMGR configuration have ldev numbers permanently assigned. The DTC devices can then be accessed programmatically through use of their ldev number. Non-nailed devices have ldev numbers that are assigned from a pool of available ldev numbers for the life of their connection to a system. Each nailed port configured in NMMGR must have a unique ldev number.

**log off** The termination of a job or session. unique ldev number.

**log on** The process of initiating a job or session.

**logon device** *See* **session-accepting device**.

**loopback** The routing of messages from a node back to itself.

**LUG** Local User Group. A list defined for a particular DTC and card that specifies which *remote* nodes this DTC can send data to and also which *remote* nodes this DTC can receive data from. *See also* **Closed User Group**.

## M

**map, network** A drawing that shows the topology of the network. For networks managed by the OpenView DTC Manager a network map must be created through use of the OVDRAW capability provided with the management software. A network map is also a hardcopy drawing used when planning a network. It shows network topology, node and network names, addresses, network boundaries (for an internetwork map), and link types.

**mapping** A set of characteristics that describe a route taken by messages to reach a destination node. This set of characteristics is configured with NMMGR at every node on a point-to-point network. One mapping is configured at each node for every other node on the network to which messages will be sent.

**MAU** Medium Attachment Unit. A device attached to a ThickLAN coaxial cable that provides the physical and electrical connection from the AUI cable to the coaxial cable.

**M bit** More data bit. Setting this bit in a DATA packet indicates that at least one more DATA packet is required to complete a message of contiguous data.

**MDP** Modem Distribution Panel; a distribution panel that serves as the electrical and physical interface between a DTC 72MX mux board (asynchronous processor board) and up to eight asynchronous devices for direct or modem connections. Also called **ADP**.

**MIT** Master Installation Tape. A magnetic tape containing the Fundamental Operating System for an HP 3000 Series 900 computer.

**modem** modulator/demodulator. A device that modulates and demodulates signals. Primarily used for modulating digital signals onto carriers for transmission and for performing the inverse function at the receiving end. Modems are essential for transmitting and receiving digital signals over telephone lines.

**modulo** Value used as the counting cycle for determining the send sequence number (N(S)) of frames sent across an X.25 network.

**modulation** The process in which certain characteristics of a carrier signal are altered in accordance with the changes of an information-bearing signal.

**MPE/iX** MultiProgramming Executive iX The operating system of the HP 3000 Series 900 computers. The NS 3000/iX network services operate in conjunction with the MPE/iX operating system.

**multiplexer** MUX. A device that allows multiple communication links to use a single channel.

## N

**nailed device** A device with a permanently assigned ldev. The assignment is established through the system configuration of the MPE/iX host system. Nailed devices can be accessed programmatically through their ldev number. Nailed devices can also be assigned to more than one host.

**native mode** The run-time environment of MPE/iX. In Native Mode, source code has been compiled into the native instruction set of the HP 3000 Series 900 computer.

**neighbor gateway** A gateway that is in the same network as a given node.

**NetIPC** Network Interprocess Communication. Software that enables programs to access network transport protocols.

**network** A group of computers connected so that they can exchange information and share resources.

**network address** This can be either 1) the network portion of an IP address as opposed to the node portion, or 2) when referring to X.25 networks, it is a node's X.25 address.

**network boundary** The logical division between networks in an internetwork.

**network directory** A file containing information required for one node to communicate with other nodes in 1) an internetwork, 2) an X.25 network, or 3) a network that contains non-HP nodes. The active network directory on a node must be named NSDIR.NET.SYS.

**network interface** NI. The collective software that enables data communication between a system and a network. A node possesses one or more network interfaces for each of the networks to which it belongs. Network interface types are LAN802.3, router (point-to-point), X.25, loopback, and gateway half. The maximum number of supported NIs is 12, one of which is reserved for loopback.

**network management** The collective tasks required to design, install, configure, maintain, and if necessary, change a network.

**network map** A drawing that shows the topology of the network. For networks managed by the OpenView DTC Manager, a network map must be created using the OVDRAW capability provided with the management software.

**Network Services NS.** Software application products that can be used to access data, initiate processes, and exchange information among nodes in the network. The HP 3000/iX Network Services include RPM, VT, RFA, RDBA, and NFT.

**network subscribed facilities** A set of parameters that the user chooses when he subscribes to the X.25 network; they include Flow Control Negotiation, Use of D-bit, Throughput Class Negotiation and Extended Packet Sequence Numbering.

**NFT** Network File Transfer. The network service that transfers disc files between nodes on a network.

**NI** See **network interface**.

**NLP** Name Lookup Protocol. A protocol used when setting up links between DTCs, as happens when DTCs are used in a back-to-back configuration.

**NMCONFIG.PUB.SYS** The file that contains all of the network configuration data for the HP 3000 Series 900 computer on which it resides. It includes information about the DTCs that can access the system as well as information about any Network Service (NS) products running on the system. This is the only file name allowed at run-time.

**NMDUMP** A utility used to format log and trace files.

**NMMAINT** A utility that lists the software module version numbers for all HP AdvanceNet products, including NS 3000/iX. It detects missing or invalid software modules.

**NMMGR** Node Management Services Configuration Manager. A software subsystem that enables you to configure DTC connectivity and network access parameters for an HP 3000 Series 900 computer.

**NMMGRVER** A conversion program called NMMGRVER.PUB.SYS. It converts configuration files created with NMMGR from an earlier version to the latest format.

**NMSAMP1.PUB.SYS** A sample configuration file supplied with FOS that can be used as a template for DTS configuration.

**node** A computer that is part of a network. The DTC is also considered to be a node and has its own address.

**node address** The node portion of an IP address. The IP address consists of a node portion and a network portion.

**Node Management Services Configuration Manager** See **NMMGR**.

**node name** A character string that uniquely identifies each system in a network or internetwork. Each node name in a network or internetwork must be unique; however, a single node can be identified by more than one node name.

**node names list** A list defined on the OpenView windows workstation and subsequently downloaded to all DTCs for which it is the "owner." The list specifies all of the HP 3000 Series 900 hosts on the LAN that are accessible from the DTCs.

**non-adjacent** Describes a node on an NS Point-to-Point 3000/iX network that is separated from a given node by intervening or intermediate node.

**non-nailed device** A session-accepting device that is not permanently associated with an ldev number at configuration time. When the user at such a device logs on to an MPE/iX system, an ldev is assigned from a pool of ldevs set aside for this purpose at configuration time. The association between a non-nailed device and this assigned ldev exists only for the duration of the session. One advantage of the use of non-nailed device connections is that configuration is simplified, since it is not required that each non-nailed device be individually configured.

**NS 3000/iX** A Hewlett-Packard data communication product that provides networking capabilities for MPE/iX based HP 3000 minicomputers. NS 3000/iX consists of a link and network services.

**NS 3000/iX Link** Software and hardware that provides the connection between nodes on a network. Some of the NS 3000/iX links available are the ThinLAN 3000/iX Link and its ThickLAN option,

the DTC/X.25 iX Network Link, the NS Point-to-Point 3000/iX Link, and the StarLAN 10 3000/iX link.

**NS 3000/iX Network Services Software** applications that can be used to access data, initiate processes, and exchange information among nodes in a network. The services are RPM, VT, RFA, RDBA, and NFT.

**NSDIR.NET.SYS** Name of the active network directory file. *See also* **network directory**.

## O

**octet** An eight-bit byte operated upon as an entity.

**OpenView** HP OpenView Windows is HP's network management environment. It provides the basic services for accessing and managing networks used by the DTC Manager, and other applications, such as Switch/PAD Manager, Hub Manager, etc.

**OpenView Admin** An OpenView Windows program that enables you to configure how your OpenView Windows applications will function. For example, it enables you to set a default map for the OpenView DTC Manager.

**OpenView Draw** An OpenView windows program that is used to draw the network map and to label the components on it.

**OpenView DTC Manager** An OpenView Windows application that enables you to configure, control, monitor, and troubleshoot the operation of the Distributed Terminal Subsystems on the LAN.

**OpenView Run** An OpenView windows program that covers most of the control features used by the DTC Manager, including monitoring and diagnostic functions.

**OpenView Windows** The set of three programs: OV Admin, OV Draw and OV Run, running on the OpenView workstation under MS Windows, that acts as the platform for all OpenView applications, such as DTC Manager.

**OpenView Windows Workstation** The personal computer that provides software downloads to enable operation of the Datacommunications and

Terminal Controller (DTC). The configuration software that runs on this workstation is called the OpenView DTC Manager software.

**OSI model** Open Systems Interconnection model. A model of network architecture devised by the International Standards Organization (ISO). The OSI model defines seven layers of a network architecture with each layer performing specified functions.

## P

**packet** A block of data whose maximum length is fixed. The unit of information exchanged by X.25 at Level 3. The types of packets are DATA packets and various control packets. A packet type is identified by the encoding of its header.

**Packet Exchange Protocol PXP** A transport layer protocol used in NS 3000/iX links to initially establish communication between nodes when NetIPC socket registry is used.

**packet-switched network name** The name of a data communication network adhering to the CCITT X.25 recommendation. This can be a PDN or a private network such as the HP PPN.

**PAD (packet assembler/disassembler)** A device that converts asynchronous character streams into packets that can be transmitted over a packet switching network (PSN).

**PAD name** A name of up to eight characters that is associated with a configured PAD device. The PAD name is known to both the DTC (defined by the DTC Manager) and the MPE/iX systems (defined by NMMGR) that the device can access.

**PAD profile** A terminal or printer profile that specifies the configuration characteristics for PAD-connected devices.

**PAD support** A software module which can be downloaded to an X.25 board in a DTC. The software is used to manage connections with remote PAD devices.

**partner gateway half** When gateway halves are used, two gateway halves are required in order to provide communication between two networks. Each is the partner of the other.

**path name** When configuring with NMMGR, you can type a string in the `COMMAND:` field on a screen to branch to another screen. Each screen has a unique path name that corresponds to its location in the hierarchy of configuration screens presented by NMMGR.

**PDN** Public data network. A data communication network whose services are available to any user willing to pay for them. Most PDNs use packet switching techniques.

**point-to-point** A link that connects either two nodes in a NS Point-to-Point 3000/iX network or two gateway halves.

**port** An outlet through which a device can be connected to a computer, consisting of a physical connection point and controlling hardware, controlling software, and configurable port characteristics. Ports can be thought of as data paths through which a device communicates with the computer.

**Precision Architecture** The hardware design structure for the HP 3000 Series 900 computer family.

**printer name** A character string of up to 16 characters specified in the DTC Manager configuration (for networks using OpenView Network Management) to define a printer by name. Can be shared by several printers (port pool).

**printer profile** A set of configuration characteristics that can be associated with one or more printers through the NMMGR configuration. Printer profile specifications include the printer type, line speed, device class assignment, and other values relevant to printers connected through a DTC.

**printer type** A set of configuration characteristics that cause a printer connected to an MPE/iX system to act and react in a specified manner. You can configure a printer to use one of the system-supplied printer types, or you can create custom printer types using Workstation Configurator.

**privileged mode** A capability assigned to accounts, groups, or users allowing unrestricted memory access, access to privileged CPU instructions, and the ability to call privileged procedures.

**probe protocol** An HP protocol used by NS 3000/iX IEEE 802.3 networks to obtain information about other nodes on the network.

**probe proxy server** A node on an IEEE 802.3 network that possesses a network directory. A probe proxy server can provide a node with information about other nodes on the same or other networks of an internetwork.

**profile** A method of grouping device connection specifications and characteristics so that the set of characteristics can be easily associated with groups of like devices. *See also* **printer profile**, **terminal profile**.

**program captive device** *See* **programmatic device**.

**Programmable Serial Interface** PSI. A hardware card that fits into the backplane of the HP 3000 Series 900 computer. It provides a physical layer interface for NS Point-to-Point 3000/iX Links.

**programmatic device** PSI. A device operating under control of a program running on a computer. Programmatic devices can be used for input, output, or both, depending on the device and how it is opened by the controlling program.

**protocol** A set of rules that enables two or more data processing entities to exchange information. In networks, protocols are the rules that govern each layer of network architecture. They define which functions are to be performed and how messages are to be exchanged.

**PSN** Packet-Switching Network. Any data communication network in which data is disassembled into packets at a source interface and reassembled into a data stream at a destination interface. A public PSN offers the service to any paying customer.

**PSS** Packet-Switching System. The national public PSN of the United Kingdom.

**PVC** Permanent Virtual Circuit. A permanent logical association between two physically separate DTEs that does not require call set-up or clearing procedures.

**Q bit** *See* **Packet Exchange Protocol**.



**Q**

**Q bit** Qualified bit. When set in DATA packets the Q bit signifies that the packet's user data is a control signal for the remote device, not a message for its user.

**QuickVal** A software program that tests whether Network Services are operating correctly between nodes.

**R**

**RDBA** Remote Data Base Access. A network service that allows users to access data bases on remote nodes.

**reachable network** A network that can be accessed (with additional internet hops possibly required) by a particular gateway.

**remote connect device** An asynchronous device that is indirectly connected to a DTC through a modem and telephone hook-up or through a PAD.

**remote node** Any network node that is physically separate from the node you are currently using or referring to.

**retransmission count (N2)** The maximum number of times a frame will be retransmitted following the expiration of the Retransmission Timer, T1.

**retransmission count (T!)** The length of time that a transmitter will wait for an acknowledgment from a destination address before attempting to retransmit a frame. When choosing this value, factors like the line speed and maximum frame size should be taken into account.

**RFA** Remote File Access. A network service that allows users to access file and devices on remote nodes.

**routing** The path that packets or fragments of a message take through a network to reach a destination node.

**RMP** Remote Maintenance Protocol. HP proprietary protocol used in DTC management.

**RPM** Remote Process Management. A network service that allows a process to programmatically initiate and terminate other processes throughout a network from any node on the network.

**RS-232-C** The Electronic Industries Association (EIA) Level 1 protocol specification that defines electrical circuit functions for 25 connector pins. HP provides two implementations of this standard: a 3-pin version for direct connections up to a distance of 15 meters (50 feet), and a version which makes use of additional circuits and can be used for either modem or direct connections.

**RS-422** The Electronic Industries Association (EIA) Level 1 protocol specification implemented by HP in a 5-pin version which can be used for direct device connection up to a distance of 1500 meters (4000 feet).

**S**

**security string** An alphanumeric character string that functions as a password for dial links. The security string is used by the Dial IP protocol.

**serial device** Any device that is attached to and communicates with a computer by means of a serial transmission interface. Terminals, printers, and plotters are among the devices that communicate serially with MPE/iX computers.

**serial transmission** A method of transferring data in which characters are transmitted one bit at a time and received one bit at a time in the order of transmission. This transmission scheme is employed by devices connected to the MPE/iX systems via the DTC.

**session-accepting device** A terminal or personal computer running in terminal-emulation mode that is able to establish an interactive (conversational) session with an HP 3000 computer. Also referred to as a logon device.

**shared dial** A dial link that provides connection to more than one remote system, although to only one at a time.

**shared-line access** The feature that allows two or more HP 3000 Series 900 hosts to use the same DTC/X.25 Network Access card on a DTC to access an X.25 network.

**SIC** Serial Interface Card. A card installed in the front of the DTC that acts as an interface between a corresponding Connector Card (CC) and the DTC's processor.

**slaved device** A device that shares the same DTC port as another device and is connected, to the other device, referred to as its master, by a cable. The actions of the slaved device are controlled by the master device.

**SNMP** Simple Network Management Protocol. An industry standard, for managing networked computers in a multi-vendor environment.

**SNP** Synchronous Network Processor card; an alternative name for an X.25 board.

**spooled device** A printer that is accessed through the MPE/iX spooling facility. The spooling facility allows a nonsharable device to be shared among several users by temporarily storing output data on disc and managing the selection of output spool files destined for the spooled device.

**start bit** A data bit used to signal the start of a character being transmitted in an asynchronous communication mode.

**station address** A link-level address used by the IEEE 802.3 protocol that is assigned to every node on an IEEE 802.3 network.

**stop bit** A data bit used to signal the end of a character being transmitted in an asynchronous communication mode.

**store-and-forward** A technique in which messages are passed from one node to another in a network to reach their destination. Point-to-point networks use the store-and-forward technique to transmit messages.

**subnet** Another name for a network, especially if the network is part of an internetwork. The word subnet is also a synonym for intranet.

**SVC** Switched Virtual Circuit. The path through an X.25 network that is established at call set-up time.

**switching** *See* **DTC switching**.

**Switching User Interface** The user interface available when DTC switching is enabled that allows terminal users to choose the MPE/iX computer with which they want to establish a communication link.

**synchronous** A mode of operation or transmission in which a continuous data stream is generated without intervals between characters. The data stream is synchronized by clock signals at the receiver and transmitter. As a result, fast transmission speeds (above 9600 bps) are attainable.

**SYSGEN** The software program that allows you to configure the operating system on HP 3000 Series 900 computers.

**system configuration** The method for telling MPE/iX which peripheral I/O devices are attached to the DTC and which parameters are required for system operation.

## T

**TCP** *See* **Transmission Control Protocol**.

**Telnet** A proprietary public data network in the USA.

**Telnet Access Card (TAC)** A card that resides in the DTC 48 and provides protocol conversion between Telnet and AFCP.

**Telnet Express** *See* **HP ARPA Telnet Express**.

**TermDSM** Terminal Online Diagnostic System Manager. A utility that provides diagnostic services for DTC connections by means of a series of commands accessible through the `SYSDIAG` utility. TermDSM is used only when DTCs are managed by an MPE/iX host system.

**terminal name** A character string of up to 16 characters specified in the OpenView DTC Manager configuration (for networks using OpenView Network Management) to define a terminal by name. It can be shared by several terminals (pool port)

**terminal profile** A set of configuration characteristics that can be associated with one or more terminals through the NMMGR configuration. Terminal profile specifications include the terminal

type, line speed, device class assignment, and other values relevant to terminals connected through a DTC.

**terminal type** A collection of characteristics that cause a terminal connected to an MPE/iX system to act and react in a specified manner. You can configure a terminal to use one of the system-supplied terminal types, or you can create custom terminal types using the Workstation Configurator.

**ThinLAN 3000/iX** A LAN that conforms to the IEEE 802.3 Type 10 BASE 2 standard LAN.

**throughput class** A value assigned to a given virtual circuit that defines how many network resources should be assigned to a given call. It is determined by the access line speed, packet and window sizes, and the local network's internal mechanisms.

**throughput class negotiation** One of the Network Subscribed Facilities defined at subscription time. This allows the user to negotiate the Throughput Class at call set-up time.

**timer (T3)** The length of time that a link can remain in an idle state. After the expiration of the timer, the link is considered to be in a non-active, non-operational state and is automatically reset. The value should be chosen carefully. In particular, it must be sufficiently greater than the Retransmission Timer (T1) so that no doubt exists about the link's state.

**topology** The physical arrangement of nodes in a network. Some common topologies are bus, star, and ring.

**Transmission Control Protocol** TCP. A network protocol that establishes and maintains connections between nodes. TCP regulates the flow of data, breaks messages into smaller fragments if necessary (and reassembles the fragments at the destination), detects errors, and retransmits messages if errors have been detected.

**Transpac** TCP. The national public PSN of France.

**transparent mode** A data-transfer scheme in which only a limited number of special characters retain their meaning and are acted on by the system.

All other characters are considered to be data and are passed through with no control actions being taken.

**transport, network** Software that corresponds to layers 3 and 4 of the OSI network architecture model. It sends data out over the communications link, receives incoming data, and routes incoming or outgoing data to the appropriate destination node.

**TS8** *See* **HP TS8**.

**TTUTIL** Also known as the Workstation Configurator. A program, `TTUTIL.PUB.SYS`, on the HP 3000 that is used to create and modify terminal and printer type files.

**Tymnet** A proprietary public data network in the USA.

**Typeahead** A facility that allows terminal users to enter data before a read is actually posted to the terminal.

## U

**unacknowledged frame number (K)** The number of frames that can be transmitted without receiving an acknowledgment from the destination address. When this number (K) frame is reached, the same K frames are retransmitted.

**unedited mode** *See* **transparent mode**.

## V

**V24** The CCITT recommendation that defines the function of the interchange circuits between a DTE and a DCE.

**validation** The process of ascertaining whether the network transport configuration file has been correctly configured. This is accomplished by using the NMMGR Validate Configuration File screen

**VAN** Value-Added Network. A data communication network that uses and pays for facilities belonging to another carrier. The value-added package is then sold to a user.

**VC** *See* **virtual circuit**.



**virtual circuit** A logical association between two physically separate DTEs.

**virtual circuit** A logical association between two physically separate DTEs.

**Virtual Terminal** A network service that allows a user to establish interactive sessions on a node.

**VPLUS** Software used to generate screens such as those displayed by NMMGR.

**V-Series (V.##) CCITT** A set of CCITT recommendations related to data communication over a voice-grade telephone network.

**VT** See **Virtual Terminal**.

## W

**WAN** Wide Area Network. A data communications network of unlimited size, used for connecting localities, cities, and countries.

**Workstation Configurator** A utility available on MPE/iX systems, TTUTIL.PUB.SYS, that allows users to create customized terminal and printer types by entering data through a series of VPLUS screens.

## X

**X.3** The protocol that defines which user facilities should be internationally available from a packet assembler/disassembler (PAD) when this is offered by a public data network.

**X.21** The protocol that defines the physical interface between a DTE and a DCE of a public data network where the access to the network is made over synchronous digital lines.

**X.25** The protocol that defines the interface between a DTE and a DCE for packet-mode operation on a Public Data Network (PDN).

**X.25 address** The X.25 address provided by the network administration if you are connected to a public data network (PDN).

**X.25 address key** An X.25 address key is a label that maps a node's IP address to its X.25 address and its associated X.25 parameters. You have a combined maximum of 1024 X.25 address keys in the SVC and PVC path tables.

**X.25 LUG address** X.25 address of a node belonging to a LUG.

**X.25 iX System Access** The software that works in conjunction with the DTC/X.25 Network Access software to provide MPE/iX access to X.25. The software resides on an HP 3000 host and is configured through use of NMMGR. To configure access to an X.25 network, you must configure two software components: the X.25 iX System Access and the DTC/X.25 Network Access (residing on the Datacommunications and Terminal Controller and configured at the OpenView Windows Workstation). Together, these two components provide a network connection on HP 3000 systems to private and public X.25 packet-switched networks (PSNs).

**X.29** The protocol that defines the interface for data exchange between a packet-mode DTE and a remote Packet Assembly/Disassembly (PAD) facility over a packet-switching network.

**XON/XOFF protocol** The flow control used by MPE/iX systems to protect against data overruns. XON/XOFF protocol is controlled by the data recipient who sends an XOFF character (ASCII DC3) to the sender if it is unable to continue to receive data. The sender suspends transmission until it receives an XON character (ASCII DC1).

**X.Series (X.##) CCITT recommendations** A set of recommendations for data communication networks governing their services, facilities, and terminal equipment operation and interfaces.



**Numerics**

10Base-T, 20  
25-pin connectors, 34  
25-pin RS-232, 17  
3-pin connectors, 34  
3-pin RS-232, 17  
5-pin connectors, 34  
5-pin RS-422, 17

**A**

abort sessions, 34  
aborting sessions, 36  
access port, 16  
application software, 22, 25  
ASC, 33  
Asynchronous Serial Communications  
ASC, 20  
asynchronous serial devices, 16, 33, 34

**B**

block mode, 21, 22  
BNCT-connector, 19

**C**

cabinet space, 16  
character mode, 21, 22  
coaxial cable, 18  
collect information, 22  
command-based utility, 36  
COMMENT command, 37  
configuration, 18  
files, 20  
information, 17, 36  
connector card, 34

**D**

data loss, 21  
Datacommunications and Terminal Controller  
DTC, 16  
device, 29, 36  
cable, 28, 29  
DIAG command, 37, 45  
External, 45  
Internal, 46  
Print, 47  
Selftest, 49  
Terminal, 50  
XExternal, 52  
XInternal, 51  
XNetwork, 53  
Diagnostic user Interface prompt, 39  
diagnostics, 29  
direct-connect sessions, 21  
download, 21  
DTC, 16, 17, 19, 23, 33, 36  
DTC command, 37, 55  
DTC components, 28  
DTC operating code, 17  
DTC powerfail, 21  
DTC processor card, 31

DTC selftest, 21, 23  
DTC/X.25 Network Access Card, 17  
DTS hardware, 20  
dump, 29  
file, 29, 31  
functions, 29  
DUMP command, 37, 56  
DTC, 57  
Ldev, 58  
Mux, 59  
Port, 59  
SNP, 60  
VC, 61

**E**

EEPROM command, 37, 62  
EXIT command, 37, 63  
External Port Loopback Test, 29

**F**

Field Replaceable Units (FRU), 31

**H**

hard reset, 28  
hardware, 31, 33  
connections, 33  
diagnostics, 23  
HELP command, 37, 64  
host powerfail, 21  
host software, 16  
host-based management, 17

**I**

IEEE 802.3 standard, 18  
intermittent problems, 23  
Internal Port Loopback Test, 29

**L**

LAN, 18, 23, 32, 34  
LAN address, 18  
LAN cable, 16, 19  
LAN hardware, 25, 32  
LAN Interface Card, 16  
LANIC, 18  
LANIC, 18  
ldev number, 22  
level 3 trace, 81  
Local Area Network  
LAN, 18  
local devices, 17  
logical device number  
ldev number, 22  
loopback, 23  
loopback connectors, 34  
loss of data, 34

**M**

mainframe configuration, 34  
modems, 17  
cards, 34

---

# Index

check, 22  
connections, 21

## N

NMMGR, 20  
node address, 18  
Node Management Configuration Manager  
  NMMGR, 20  
nodes, 18

## P

parity sensing, 28  
PC-based management, 17  
PCs, 25  
plotters, 25  
port, 34, 36  
port buffers, 29  
power cord, 28  
powerfail recovery, 21  
printers, 16  
  connections, 21  
Print-to-Port Test, 29

## R

remote devices, 17  
remote mode, 28  
RESET command, 37, 67  
  DTC, 67  
  Ldev, 68  
  Port, 69  
  SIC, 69  
  SNP, 70  
  VC, 70  
reset functions, 29  
RS-232-C direct-connect cards, 34  
RS-422 direct-connect cards, 34

## S

security levels, 34  
serial interface, 28  
serial interface/connector cards, 34  
serial printers, 25  
sessions, 34  
SNP  
  cards, 34  
soft reset, 28  
software, 17, 31, 33  
software faults, 29  
speed sensing, 28  
SPU, 18  
station address, 18  
STATUS command, 37, 72, 76  
  DTC, 72  
  Port, 73  
  SNP, 74  
subsystem information, 36  
SYSDIAG command, 39  
system console, 16  
system powerfail, 21  
System Processing Unit  
  SPU, 18

## T

TermDSM, 22, 29, 31, 33, 34, 35, 36  
TermDSM command  
  DIAG, 45  
  DIAG External, 45  
  DIAG Internal, 46  
  DIAG Print, 47  
  DIAG Selftest, 49  
  DIAG Terminal, 50  
  DIAG XExternal, 52  
  DIAG XInternal, 51  
  DIAG XNetwork, 53  
DTC, 55  
DUMP, 56  
DUMP DTC, 57  
DUMP Ldev, 58  
DUMP Mux, 59  
DUMP Port, 59  
DUMP SNP, 60  
DUMP VC, 61  
EEPROM DTC, 62  
EXIT, 63  
HELP, 64  
RESET, 67  
RESET DTC, 67  
RESET Ldev, 68  
RESET Port, 69  
RESET SIC, 69  
RESET SNP, 70  
RESET VC, 70  
STATUS, 72  
STATUS DTC, 72  
STATUS Port, 73  
STATUS SNP, 74  
STATUS VC, 76  
TRACE, 77  
TRACE TIO, 77, 78, 79  
TRACE X25, 79  
TRACEOFF, 78, 82, 83  
TRACEON, 80  
TRACESHOW, 79  
Terminal Online Diagnostic Support Monitor  
  TermDSM, 22  
Terminal Write/Read Test, 29  
terminals, 16, 25  
  cables, 16  
  connections, 21  
  testing DTC-device connections, 27  
  testing the DTC, 27  
  testing the LAN, 27  
ThickLAN, 18  
ThinLAN, 18, 19  
ThinLAN Connection, 19  
ThinMau (Medium Attachment Unit), 19  
TRACE command, 37, 77  
trace option, 80  
trace option 1, 80  
trace option 2, 81  
trace option 3, 81  
TRACE TIO command, 77, 78, 79

TRACE X25 command, 79

TRACEOFF

  mux ports, 78

  VC, 82

TRACEON

  mux ports, 78

  VC, 80

TRACESHOW

  mux ports, 79

troubleshooting at the device, 26

**U**

user capabilities, 34

**V**

VC trace, 80

VPLUS applications, 21

**X**

XON/XOFF protocol, 28

