



---

Central Office  
HP 9000 Series 800t

Addendum to  
**D Class Enterprise Servers**  
System Installation Guide

---



The information contained in this document is subject to change without notice.

HEWLETT-PACKARD MAKES NO WARRANTY OF ANY KIND WITH REGARD TO THE MATERIAL, INCLUDING, BUT NOT LIMITED TO THE IMPLIED WARRANTIES OF MERCHANTABILITY AND FITNESS FOR A PARTICULAR PURPOSE. Hewlett-Packard shall not be liable for errors contained herein or for incidental or consequential damages in connection with the furnishing, performance, or use of this material.

Hewlett-Packard assumes no responsibility for the use or reliability of its software on equipment that is not furnished by Hewlett-Packard.

This document contains proprietary information which is protected by copyright. All rights are reserved. No part of this document may be photocopied, reproduced, or translated to another language without the prior written consent of Hewlett-Packard Company.

Copyright © 1997 and 1998 by HEWLETT-PACKARD COMPANY

---

## Printing History

The Printing History below identifies the edition of this manual and any updates that are included. Periodically, update packages are distributed which contain replacement pages to be merged into the manual, including an updated copy of this printing history page. Also, the update may contain write-in instructions.

Each reprinting of this manual will incorporate all past updates; however, no new information will be added. Thus, the reprinted copy will be identical in content to prior printings of the same edition with its user-inserted update information. New editions of this manual will contain new information, as well as all updates.

First Edition . . . . . May 1997 . . . . .

Second Edition . . . . . May 1998 . . . . .

---

## **Preface**

The HP 9000 family of products embraces the D Class Enterprise Server line which includes Series 800t, a NEBS-compatible version. This document explains how to install the seismic rack and DC power supply which provide NEBS compatibility for the system.

## Preface

---

## Contents

### **Addendum to D Class Enterprise Servers System Installation Guide**

Contents	1-2
Purpose of this Addendum	1-3
Tools Needed	1-3
Seismic Rack Kit	1-4
Site Hazard Considerations	1-5
Installation	1-7
DC Power Supply	1-14
Connections	1-14
Safety Grounding Procedures	1-16
Specifications	1-17

### **A Regulatory/Safety Statements**

FCC Statement (USA Only)	A-2
IEC Statement (Worldwide)	A-2
International	A-3
VCCI Statement (Japan Only)	A-3
Spécification ATI Classe A (France seulement)	A-3
Product Noise Declaration (Germany Only)	A-4
EMC Regulatory	A-5
EMC Certification	A-5
EMC Labels	A-5
Safety	A-5
Safety Certification	A-5
Safety Labels	A-5

---

## Contents



---

**Addendum to *D Class Enterprise  
Servers System Installation Guide***

---

## Contents

- Purpose of this Addendum
- Seismic Rack Kit for Series 800t
- DC Power to a Series 800t

## **Purpose of this Addendum**

This addendum provides information and procedures for installation of a Hewlett-Packard 9000 Series 800t D Class Server in a Central Office. It provides information about differences between this computer and the Hewlett-Packard D Class Enterprise Server, and contains the following procedures not found in the *D Class Enterprise Servers System Installation Guide*:

- Earthquake mounting of an HP9000 Series 800t D Class Server in a Central Office equipment frame
- Connecting DC Power to an HP9000 Series 800t D Class Server

## **Tools Needed**

- Phillips head screw drivers, size # 3 and # 1
- Nut driver (or socket or open-end) size 3/8 "
- Star-point Torx drivers, size 15 and 25
- Needle-nose pliers

## Seismic Rack Kit

The HP 9000 Series 800t D Class Server can be fitted with a seismic rack mount kit for installation in a 19-inch open relay rack. This earthquake rack fulfills Bellcore requirements for Telecommunication equipment installed in a NEBS-compatible central office. Table 1 shows the parts included for this installation, and identification numbers for each component as it appears on Figures 1 through 6.

**Table 1. Earthquake Rack-Mount Components**

Description	Quantity	Item Number	Part Number
Assembly, Top Cover	1	1	Z7616-60008
Bracket, Main, Left	1	2	Z7616-00009
Bracket, Main, Right	1	3	Z7616-00010
Assembly, Panel Latch	1	4	Z7616-60005
Bezel Mount, Left	1	5	Z7616-00012
Bezel Mount, Right	1	6	Z7616-00013
Pan, Base	1	7	Z7616-00014
Support, Bezel	1	8	Z7616-00015
Bracket, Rear	2	9	Z7630-00001
Plate, Cover	2	10	Z7630-00016
Assembly, Slide, Left	1	11	Z7616-60003
Assembly, Slide, Right	1	12	Z7616-60004
Weldment, Mounting Tray	1	13	A3262-60024
Assembly, Rack, Bezel	1	14	A3262-60036
Label, Lock	1	15	Z7616-80005
Pan Screw (12-24 x .62")	20	16	2940-0289

**Table 1. Earthquake Rack-Mount Components**

Description	Quantity	Item Number	Part Number
Split Lock Washer, #12	10	17	2190-0631
Flat Washer, #12	10	18	3050-0103
Screw 10-32 x, 3/8" Torx Pan	28	19	2680-0281
Flat Washer, #10	8	20	3050-0226
Nut w/lock, 10-32	8	21	2740-0003
Screw, 6-32 thread-forming	3	22	0624-0727
Screw, 6-32 X .38" Pozi flat	4	23	2360-0196
Screw, 12-24 X .38" Pozi flat	6	24	2940-0297
Screw, 6-32 X .38" Torx Pan	5	25	C2260-20001
Ass'y, Cable Retractor	1	26	Z7616-60009
Cable Tie, 11" long	10	27	1400-0482
Clip, Bezel Attach	2 + (2 opt)	28	C2786-40002
Screw, M4 x 0.7 X 8 Torx Pan	2 + (2 opt)	29	0515-0433
Receptacle, Clip on	2	30	1390-1090

### Site Hazard Considerations

Hewlett Packard recommends the following environmental and mechanical factors for review and compliance prior to installation of equipment.

- 1.) **85°F T<sub>mra</sub>** - Manufacturer's maximum recommended ambient temp.
- 2.) **Elevated Operating Ambient Temp.** - If installed in a multi-unit rack assembly, consider air conditioning or ventilation to avoid exceeding 85° F.
- 3.) **Reduced Air Flow** - Installation of equipment in a rack should be such that the amount of air flow required for safe operation is not compromised.
- 4.) **Mechanical Loading** - Mounting of equipment in a rack should be such that no hazard exists due to *uneven mechanical loading*.

Addendum to D Class Enterprise Servers System Installation Guide  
Seismic Rack Kit

5.) **Circuit Overloading** - Please refer to the NOTE on page 16.

6.) **Reliable Earthing** - Please refer to the topic see Safety Grounding Procedures on page 16.

## Installation

Install the seismic rack kit and the HP 9000 Series 800t D Class Server into an open relay rack using the following steps. References to item numbers in these steps pertain to the item numbers listed in Table 1.

- 1 Unpack the rack-mount kit and check the hardware, using the parts list in Table 1 on page 4 and the illustrations in this procedure to ensure that all the required parts are present.
- 2 Remove the standard front bezel (narrow) that was shipped installed on the computer. It is hinged at the top and secured by split molded posts which fit into openings in the metal-work. It can be removed by pulling outward at the bottom edge and lifting the top edge off the hinges.
- 3 Remove the emblem insert and the door from the standard bezel. These items will be transferred to the wide bezel in a later step.
  - The molded plastic emblem insert has three tapered split-post protrusions on the back, which insert into matching holes on the cover and spread apart when inserted to provide an interference fit. A convenient tool for compressing the split retainers is a pair of needle-nose pliers. Start at one end and push out on the emblem insert as you compress each split-post retainer from the rear.
  - The plastic door is pivoted in each corner on its left edge. Open the door and flex it carefully, forming a slight bow near the center on the inside edge, to pop the molded plastic pin on the bezel out of the molded socket on the bottom of the door. See Figure 1 on next page.
- 4 To locate the position within the rack for installing the seismic rack kit, allow 5/8 " above the top-most hole in the vertical channels needed for attaching the main bracket panels. For example, to install the kit so that the top edge of its front bezel is flush with the bottom edge of existing equipment in the rack, measure 5/8 " below that bottom edge and note the corresponding hole in the vertical channel.

**Figure 1. Seismic Rack Installation**

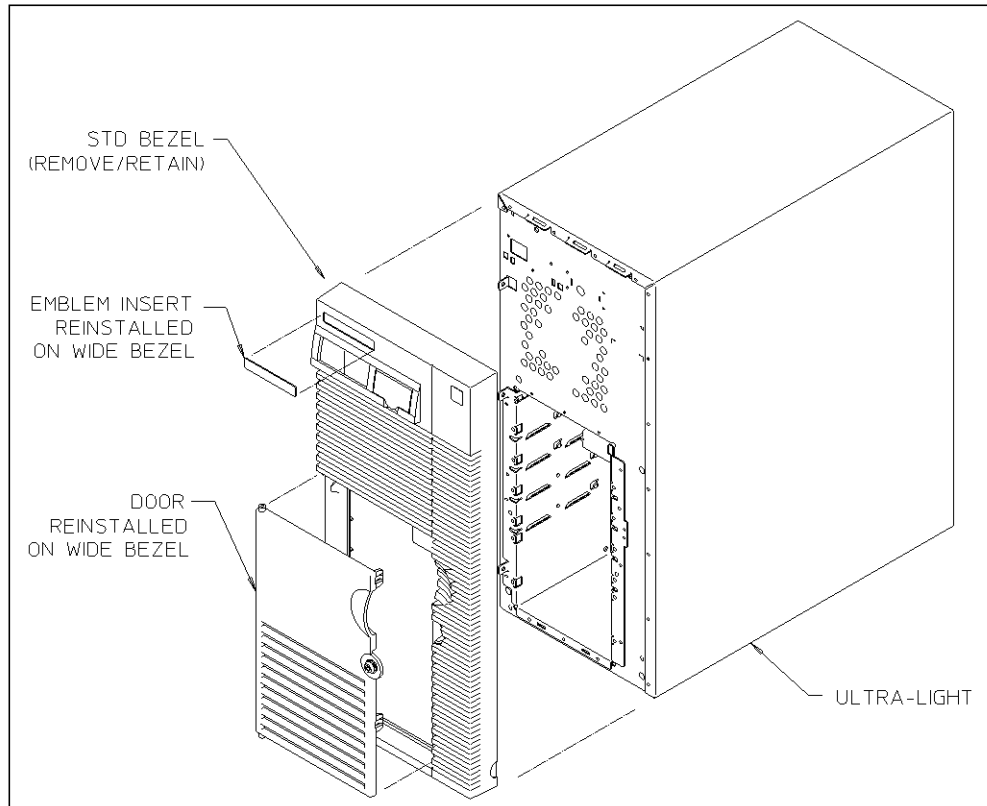

- 5 Attach the right and left main bracket panels (items 2, 3 in Figure 2) to the vertical mounting rails of the relay rack, using hardware item 24, Table 1. The bracket panel is oriented top to bottom as shown in Figure 2 on the next page. Align the upper counter-sunk hole on the panel with the hole in the vertical channel that was noted in the previous step.
- 6 Attach the rear brackets (Figure 2 item 9, 2 places) to the right and left main brackets, using item 19 hardware in three places as shown. Attach to rear of relay rack using hardware items 16, 17, and 18 (4 pls each side).
- 7 Assemble base pan (Figure 2 item 7) to lower row of holes on main brackets, but do not tighten the hardware yet. With pan positioned between the main bracket panels from the rear, raise it to align the holes as needed. Use item 19 hardware in four places on each bracket. Use the item 16, 17, 18 hardware to fasten each side of the pan to the vertical channel (2 pls).



Figure 2. Seismic Rack Installation

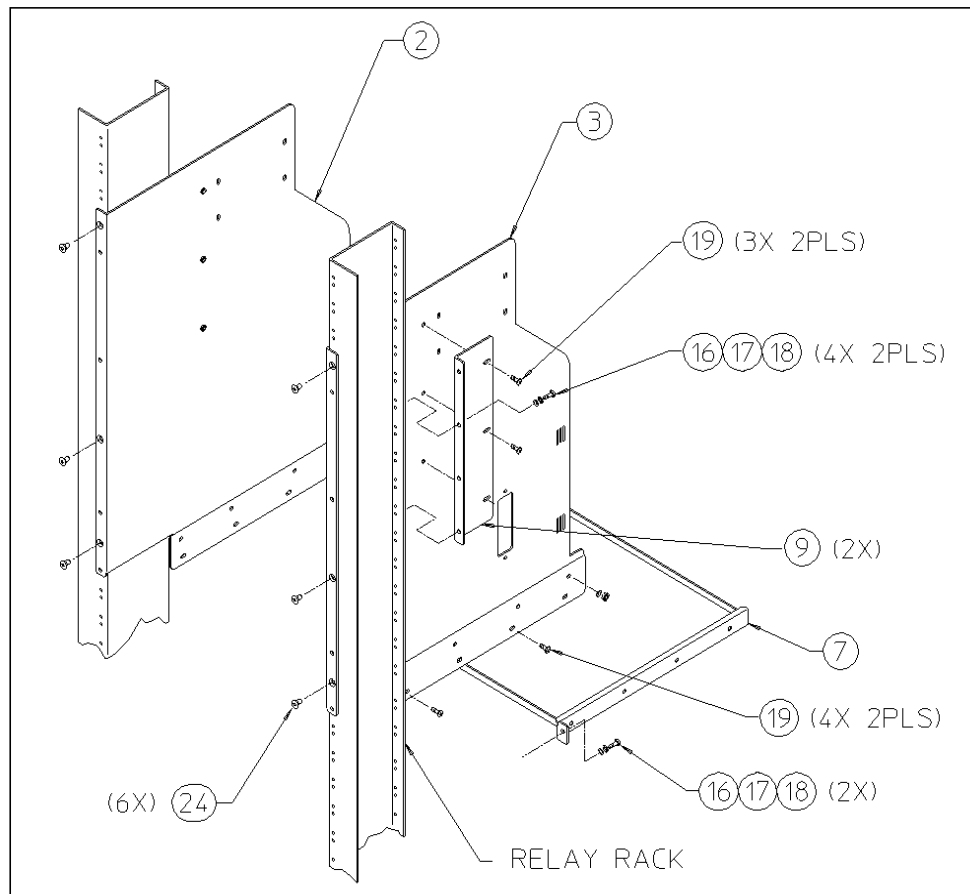

Addendum to D Class Enterprise Servers System Installation Guide  
**Installation**

- 8 Using item 16 screws (only) attach the bezel mount brackets (items 5, 6 in Figure 3) to the vertical rails as shown. Attach the two clip-on receptacles (item 30) at the bottom of the brackets as shown.
- 9 For full GR-63-CORE NEBS compliance, attach *only* the two bezel clips at the top of the brackets using item 29 screws. (Optionally attach two clips at the bottom as well.)
- 10 Attach the bezel support (item 8) to lower area of vertical rails using item 16 screws (only) as shown. Top edge of bezel support is flush with bottom of bezel mount brackets.
- 11 Position top cover (item 1) in upper area as shown. Install but dont tighten screws.

**Figure 3. Seismic Rack Installation**

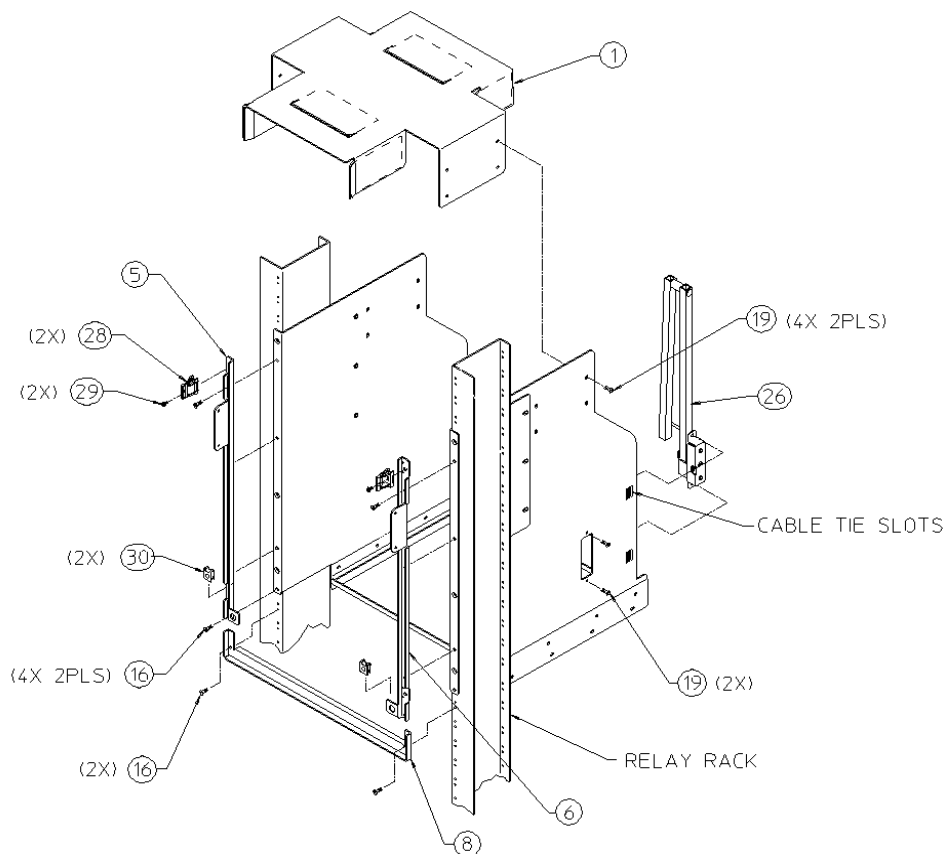

- 12 Attach cable retractor ( item 26, Figure 3) to right main bracket as shown.
- 13 Attach the slide assemblies to the main brackets using the top row of holes (above the base pan). Do not tighten the hardware (items 20, 21) yet.

**NOTE:**

These two assemblies are mirror image; ensure that they are oriented as shown.

- 14 Position the base pan, installed in step 6, to support the slides by exerting forceful upward pressure on the base pan; then secure all fasteners including on the slides.
- 15 Extend slides until they lock and position the mounting tray (item 13) to the front extensions as shown. Engage alignment pins for proper location and secure with item 19 hardware. Test for proper installation by sliding to full extent of travel in and out. (Slide release buttons are on sides of slide channels near front.)

**Figure 4. Seismic Rack Installation**

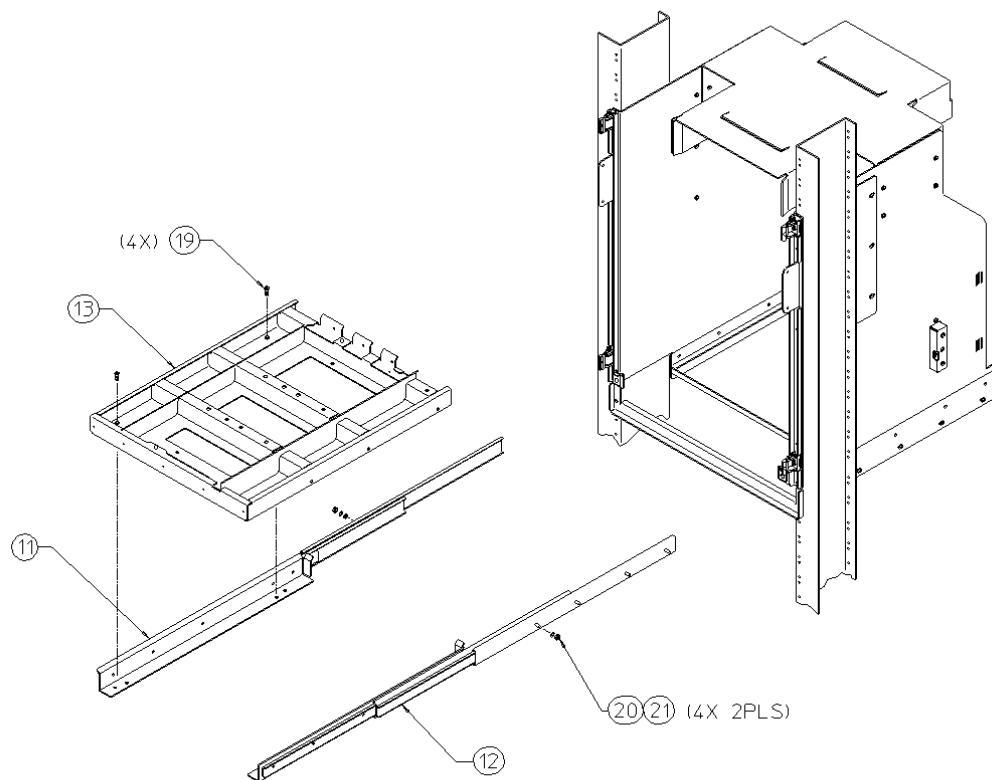

**CAUTION:**

Two people are highly recommended for this next task.

- 16 With tray extended hoist computer into position, aligning base with locator pins in tray. Slide tray and computer into rack and secure at three places with thread-forming screws (hardware item 22) at rear of tray.
- 17 Attach the latch panel (item 4) to front of mounting tray using five screws.
- 18 With the computer positioned into the rack, fasten knurled screws in latch panel to lower tabs in bezel mount brackets. NOTE: tighten *securely*.
- 19 With the computer securely engaged within the rack assembly, check alignment of top cover (ref Step 10) and tighten all fasteners.

**Figure 5. Seismic Rack Installation**

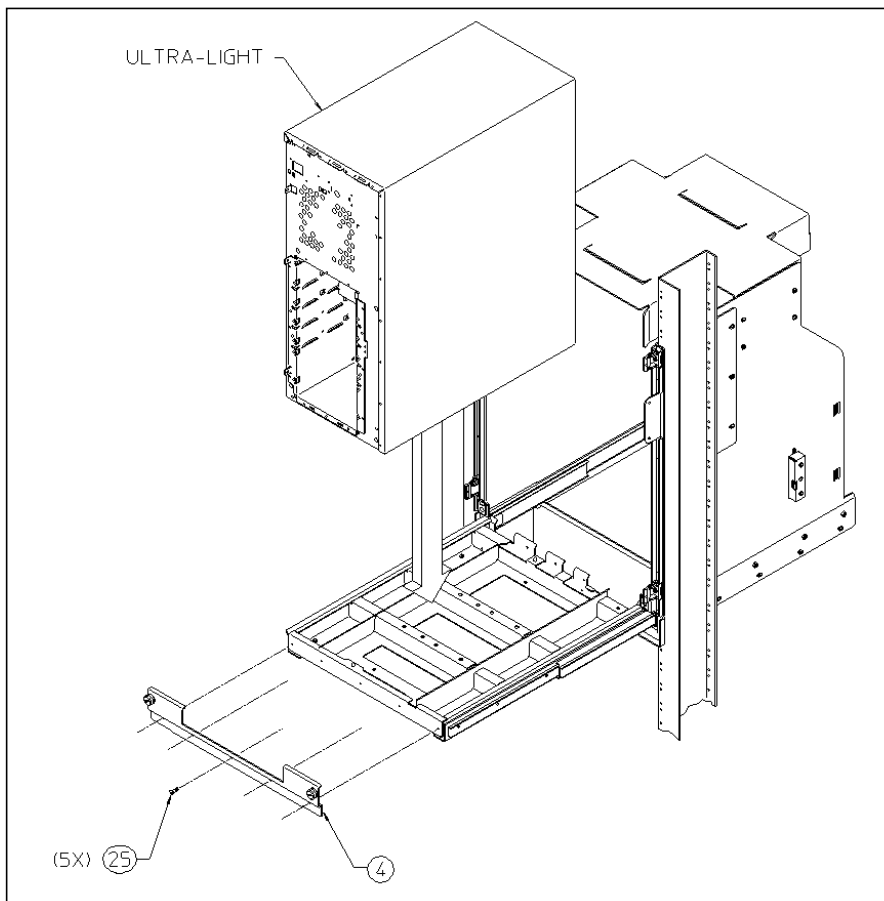

- 20 Install the emblem insert and door removed from the standard bezel (ref. Step 3) onto the wide bezel (item 14) shown below.
- 21 Remove handles from the wide bezel and position it onto the bezel mounts attached to the rack.
- 22 Apply lock label (item 15) to the front door where shown.
- 23 Secure the bezel to the bezel mounts with the cover plates (item 10, 2 places) shown in the illustration.

**Figure 6. Seismic Rack Installation**

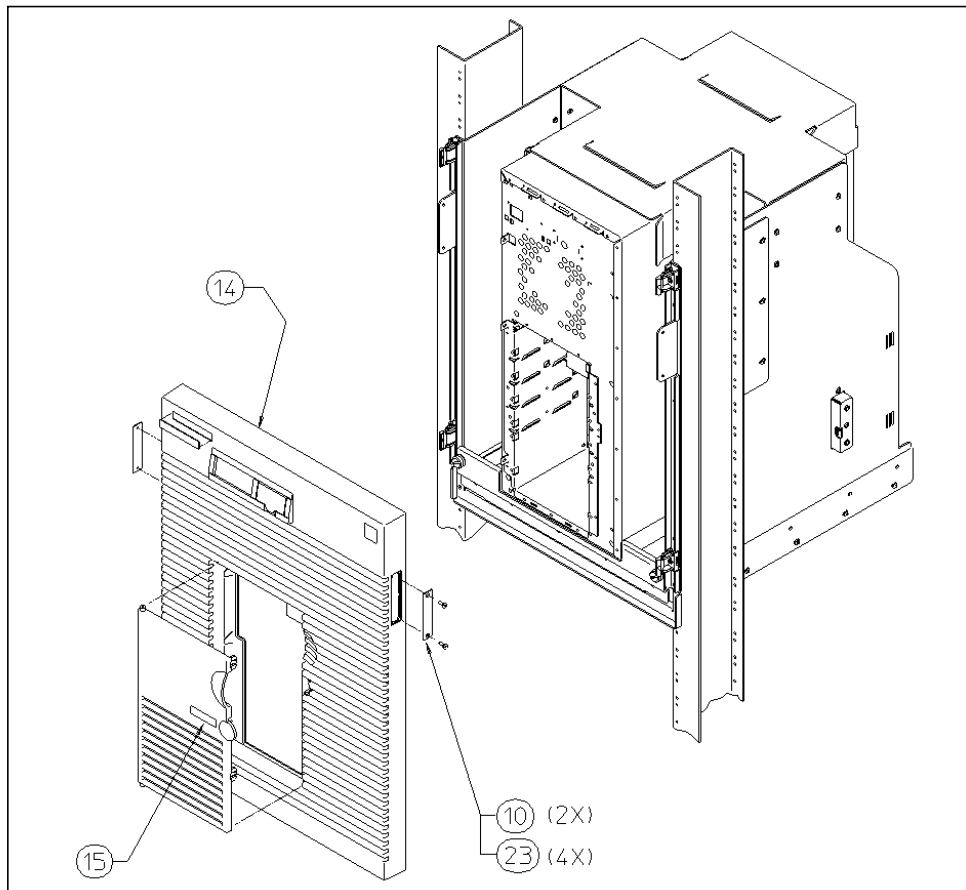

- 24 Route all cables to allow unrestricted movement of the assembly when sliding in and out. Attach wires to cable retractor (Figure 3 item 26) using cable ties (Figure 3 item 27).

## DC Power Supply

The HP 9000 Series 800t D Class Server contains a NEBS-compatible direct current (DC) power supply, rather than the alternating current (AC) power supply furnished with the standard HP 9000 D Class computer. This switching power supply is designed to work on DC by replacing the AC input module with a DC-to-DC converter module.

This DC power supply directly replaces the standard AC supply for the purpose of operating this computer from a telephone central office negative 48 volt battery or negative 60 volt battery input.

---

**WARNING:**

---

**A shock hazard exists! Do not attempt to power-up the power supply system outside the computer system chassis. The power supply requires a load and other enabling signals to operate properly.**

This DC power option provides a D Class computer server compatible to NEBS requirements for operation in a Central Office environment where equipment is powered from 48VDC batteries.

The power supply also provides alarm outputs in the form of relay contact closures to indicate a power supply failure. An additional feature provides a remote control input, which can be used to turn off the power supply for the purposes of resetting the computer system.

### Connections

The Z7634-60001 DC Power Supply comes with a 9-pin Universal Mate-N-Lock connector for power, alarm, and control circuits. A mating 9-pin plug with a 15-foot cable is supplied with the unit. The other end of the cable is bare wire to be connected to the battery plant on the site.

---

**CAUTION:**

---

The power wire assembly has been evaluated for use as internal wire only and therefore needs to be installed in a cabinet for the system to retain its safety regulatory markings.

Table 2 shows the pinouts for the site end of this cable. Figure 5 shows a diagram of the pins. The user/installer must make connections to the site installation using this information. Connect the 9-pin connector on the supplied cable to the negative 48/60 volt power supply at the rear of the system chassis.

**Table 2. DC Power Cable Pinouts**

Function	Color	Pin No
-48V (14 AWG)	Black	1
Power Supply Status (Open-OK)	White	2
Shield		3
-48V (14 AWG)	Black	4
Fan Status (Open-OK)	Red	5
Alarm Common	Green	6
-48V RTN (14 AWG)	Red	7
-48V RTN (14 AWG)	Red	8
Remote Reset (Close-reset)	Black	9

---

**WARNINGS:**

---

- 1.) The power supply cable is used as the main disconnect device for this equipment. The key switch on front of SPU does NOT disconnect the input to power supply.
  - 2.) Make sure that all central office safety precautions are carefully observed when connecting the power supply to primary power source.
  - 3.) This product is to be installed only in *Restricted Access Areas* (dedicated equipment rooms, equipment closets or the like) in accordance with Articles 110-16 to 110-18 of National Electrical Code, ANSI/NFFA 70.
-

Addendum to D Class Enterprise Servers System Installation Guide  
DC Power Supply

---

**NOTE:**

To protect the equipment from overload or short circuits that may cause equipment damage or fire, the power supply is fused internally. For added safety and integrity in the Central Office, the circuit which connects to power supply should be protected with a 30 Amp over-current fuse.

---

**Figure 5. DC Power Cable Pin Diagram**

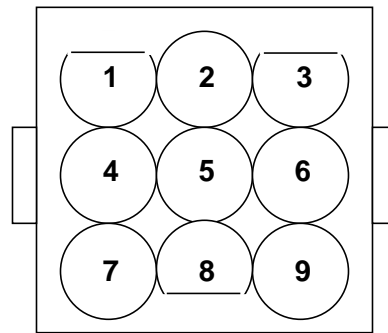

**FRONT**

**Safety Grounding Procedures**

Connect an earth ground cable to the grounding stud provided on the power supply chassis. Attach the cable to the stud using the lockwasher and nut provided. Preferably use at least a 10 AWG cable with a round eyelet crimp-lug.

---

**WARNING:**

**The computer system should at all times be connected to chassis ground. The stud has been provided near the input power connector for this purpose. Failure to connect an earth ground wire to the ground stud on the computer system will in essence leave the chassis floating, which could be hazardous to an operator because of the potential of electric shock.**

---



## Specifications

**Table 3. DC Power Specifications**

Specification	Data
Input	-48V, 20A max under full load -60V
Shutdown Thresholds	-72V (input over-voltage) -40V (input under-voltage)
Power	650W
Outputs (* = remote sense provided)	3.3V*, 25A (maximum) 5V*, 55A (maximum) 12.V, 10A (maximum) Aux5V, 55A (maximum)
Temperature Ranges: Operating:	5° to 40° C (41° to 104° F)
Non-operating:	-40° to 45°C (-40° to 113°F)
Short-term Operating:	-5° to 50°C (23° to 122°F)
Remote (switched ground) RESET signal:	-48V, 50mA (minimum) 500mA (maximum)
Alarm signals: Input out of tolerance Output out of tolerance	Dry relay contact closure for all alarms
Fused circuits: Power Input	(Not field replaceable) 30A

Addendum to D Class Enterprise Servers System Installation Guide  
**DC Power Supply**

---

**A**

---

**Regulatory/Safety Statements**

### **FCC Statement (USA Only)**

The Federal Communications Commission (in 47 CFR 15.105) has specified that the following notice be brought to the attention of the users of this product.

This equipment has been tested and found to comply with the limits for a Class A digital device, pursuant to Part 15 of the FCC Rules. These limits are designed to provide reasonable protection against harmful interference when the equipment is operated in a commercial environment. This equipment generates, uses, and can radiate radio frequency energy and, if not installed and used in accordance with the instruction manual, may cause harmful interference to radio communications. Operation of this equipment in a residential area is likely to cause harmful interference in which case the user will be required to correct the interference at his own expense. The end user of this product should be aware that any changes or modifications made to this equipment without the approval of Hewlett-Packard could result in the product not meeting the Class A limits, in which case the FCC could void the user's authority to operate the equipment.

### **IEC Statement (Worldwide)**

This is a Class A product. In a domestic environment this product may cause radio interference in which case the user may be required to take adequate measures.

---

## International

### VCCI Class A Statement (Japan Only)

この装置は、情報処理装置等電波障害自主規制協議会（VCCI）の基準に基づきクラスA情報技術装置です。この装置を家庭環境で使用すると電波妨害を引き起こすことがあります。この場合には使用者が適切な対策を講ずるよう要求されることがあります。

### Spécification ATI Classe A (France seulement)

DECLARATION D'INSTALLATION ET DE MISE EN EXPLOITATION d'un matériel de traitement de l'information (ATI), classé A en fonction des niveaux de perturbations radioélectriques émis, définis dans la norme européenne EN 55022 concernant la Compatibilité Electromagnétique.

Cher Client,

Conformément à la Réglementation Française en vigueur l'installation ou le transfert d'installation, et l'exploitation de cet appareil de classe A, doivent faire l'objet d'une déclaration (en deux exemplaires) simultanément auprès des services suivants:

Comité de Coordination des Télécommunications 20, avenue de  
Séguir - 75700 PARIS

Préfecture du département du lieu d'exploitation

Le formulaire à utiliser est disponible auprès des préfectures.

La déclaration doit être faite dans les 30 jours suivant la mise en exploitation.

Regulatory/Safety Statements  
International

Le non respect de cette obligation peut être sanctionné par les peines prévues au code des Postes et Télécommunications et celles indiquées dans la loi du 31 mai 1993 susvisée.

Arrêté du 27 Mars 1993, publié au J.O. du 28 Mars - ATI

**Product Noise Declaration (Germany Only)**

**Acoustic Noise Emissions**

LpA: 57 dB

At bystander position per ISO 7779.

All data are the results from type tests of the product configuration having the highest acoustic emissions: 8 disk drives.

All other configurations have lower emission levels.

Refer to the environmental specification section of the manual for details.

**Geräuschemission**

LpA: 57 dB

Am fiktiven Arbeitsplatz nach DIN 45635 T. 19.

Die Daten sind die Ergebnisse von Typprüfungen an Gerätekonfigurationen mit den höchsten Geräuschemissionen: 8 Plattenlaufwerke.

Alle andere Konfigurationen haben geringere Geräuschpegel.

Für weitere Angaben siehe unter Umgebungsbedingungen.

## EMC Regulatory

### EMC Certification

- < prEN 55024-2
- < prEN 55024-3
- < prEN 55024-4
- < For USA, FCC Class A, part 15
- < For Europe, CISPR-22 Level A
- < For Japan, VCCI Class A

### EMC Labels

- < CE Mark
- < FCC Statement
- < Canadian EMC Statement
- < Japanese VCCI Statement

## Safety

### Safety Certification

- < UL 1950, 2nd Edition
- < CSA 22.2 No. 950-93
- < IEC 950, 1991 2nd Edition Am. 1 and Am. 2
- < EMOKO-TUE (74) DK203
- < TUV EN60950 1992, 2nd Edition
- < SS-EN 60950 & EMKO-TSE (74-SEC)203.93
- < SSIFS 1980:2 or SS-EN 60825
- < EN 60950 1992, 2nd Edition Am. 1 and Am. 2

### Safety Labels

- UL Mark listed
- UL Mark recognized for component
- CSA Mark
- TUV/GS Mark

Regulatory/Safety Statements  
EMC Regulatory

**DECLARATION OF CONFORMITY**  
according to ISO/IEC Guide 22 and EN 45104

**Manufacturer's Name:** Hewlett-Packard Company

**Manufacturer's Address:** 8000 Foothills Blvd.  
Roseville, CA 95747, USA

**declares that the product:**

**Product Name:** PA-RISC Computer System

**Model Numbers:** HP 9000, Models Dxyz (x, y, z is any number 0-9)  
and Z76xy (x, y is any number from 0 to 9)

**Product Options:** All

**conforms to the following Product Specifications:**

**Safety:** IEC950:1991+ A1, A2, A3 / EN 60950:1992 + A1,A2, A3  
GR-63-CORE:1995, Seismic Zone 4

**EMC:** CISPR 22:1993/EN 55022:1994 - Class A2  
EN 50082-1:1992  
IEC 801-2:1991/prEN 55024-2:1992 4 kV CD, 8kV AD  
IEC 801-3:1984/prEN 55024-3:1991 3 V/m  
IEC 801-4:1988/pr EN55024-4:1992 0.5 kV Signal Lines  
1 kV Power Lines

**Supplementary Information:**

The product herewith complies with the requirements of the Low Voltage Directive 73/23/EEC and the EMC Directive 89/336/EEC and carries the CE marking accordingly.

- 1) Product models where y is equal to 0 through 5 meet the EMC directive as attested to in Certificate Number RFI/CBC1/3397A.
- 2) The product was tested in a typical configuration with Hewlett-Packard computer peripherals.

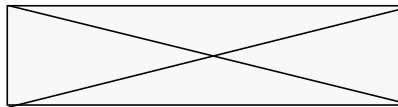

Roseville, June 25, 1997

\_\_\_\_\_  
Frank Dembski, Quality Manager

European Contact: Your local Hewlett-Packard Sales/Service Office or Hewlett-Packard GmbH,  
Department TRE, Herrenberger Strasse 130, D-71034 Boblingen, Germany (FAX: + 49-7031-14-3143)



Manual Part No. Z7634-96001

Printed in U.S.A. May 1998

